



**BLACK HORSE
OFF ROAD®**

TEL : 1-866-XANATOS

INSTALLATION INSTRUCTIONS

**TRAVELER ROOF RACK
2021-24 FORD BRONCO 4-DOOR
PART#TRRFB21**

**TRAVELER ROOF RACK
2021-24 FORD BRONCO 4-DOOR**

PARTS LIST:

1	Front Crossbar Tube	(A)	1	Driver/left Rear Foam Body Seal	(Y)
1	Front Wind Fairing LED Surround	(B)	1	Passenger/right Foam Body Seal	(Z)
2	Front Mounting Brackets	(C)	16	Hole Plugs	
2	Front Mounting Bracket Shims	(D)	4	10-1.50mm x 30mm Hex Bolts	
1	Driver/left LED "L" Bracket	(E)	4	10mm x 30mm x 2.5mm Flat washers	
1	Passenger/right LED "L" Bracket	(F)	4	10mm Lock Washer	
1	Driver/left Side Rail	(G)	4	8mm Double Nut Plates	
1	Passenger/right Side Rail	(H)	2	8-1.25 x 25mm Combo Hex Bolts	
1	Driver/left Rear Corner Tube Assembly	(I)	8	8-1.25 x 35mm Torx Button Head Bolts	
1	Passenger/right Rear Corner Tube Assembly	(J)	20	8-1.25mm x 50mm Torx Button Head Bolts	
1	Driver/left Ladder Support Tube	(K)	8	8-1.25mm x 30mm Button Head Bolts	
1	Passenger/right Ladder Support Tube	(L)	6	8-1.25 x 30mm Hex Bolts	
1	Driver/left Ladder Step	(M)	2	8-1.25 x 16mm Hex Bolts	
1	Passenger/right Ladder Step	(N)	4	8mm x 28mm x 3mm X-Large Flat Washers	
1	Rear Crossbar Tube	(O)	31	8mm x 24mm x 2mm Large Flat Washers	
4	Crossbars	(P)	4	8mm x 20mm x 2mm STD Flat Washers	
3	Offset Accessory Mounting Brackets	(Q)	40	8mm x 16mm x 1.6mm Small Flat Washers	
1	Driver/left Rear Body Mounting Bracket	(R)	18	8mm Lock Washers	
1	Passenger/right Rear Body Mounting Bracket	(S)	2	8mm Flanged Hex Nuts	
1	Driver/Left Hardtop Front Spacers	(T)	35	8mm Nylon Lock Nuts	
1	Passenger/Right Hardtop Front Spacers	(U)	4	8mm Plastic Nut Caps	
2	Hardtop Upper Top Spacers	(V)	4	6-1.0mm Flange Nuts	
1	Driver/left Hardtop Side Foam Body Seal	(W)	1	T-40 Torx Wrench	
1	Passenger/right Hardtop Side Foam Body Seal	(X)	1	5mm Wrench	
			2	50mm x 750mm Hook Loop Strips	

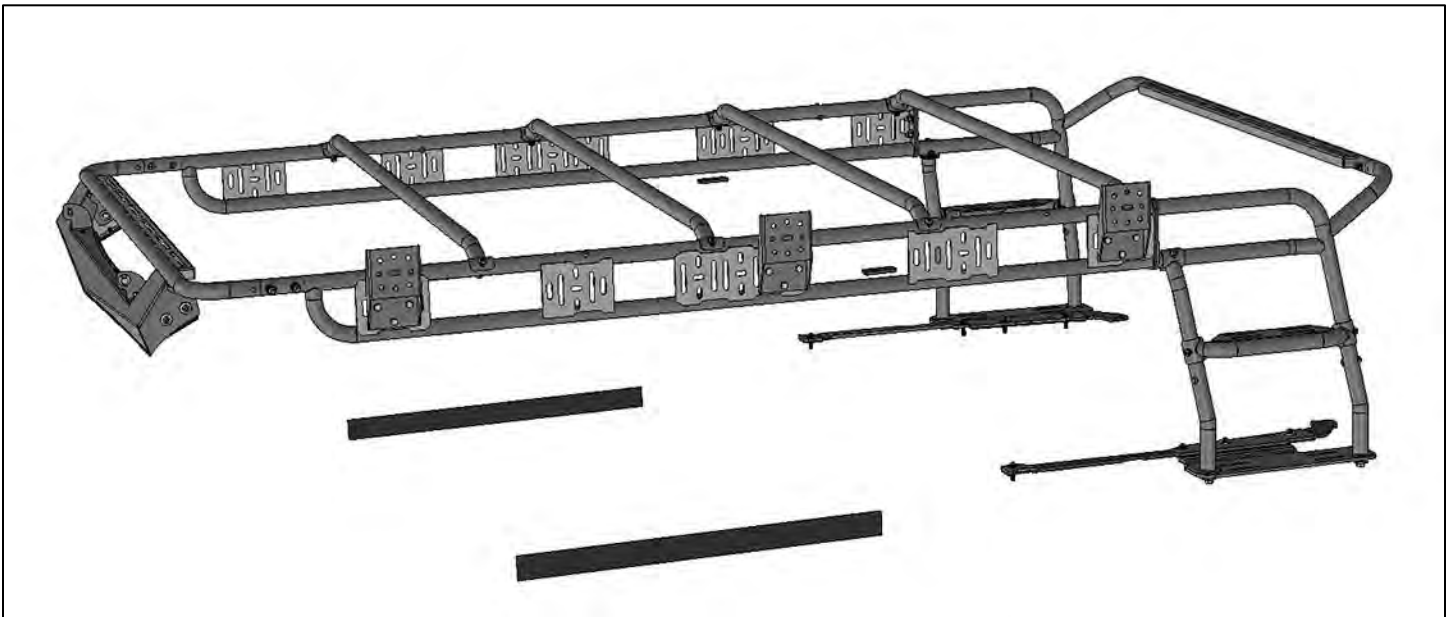

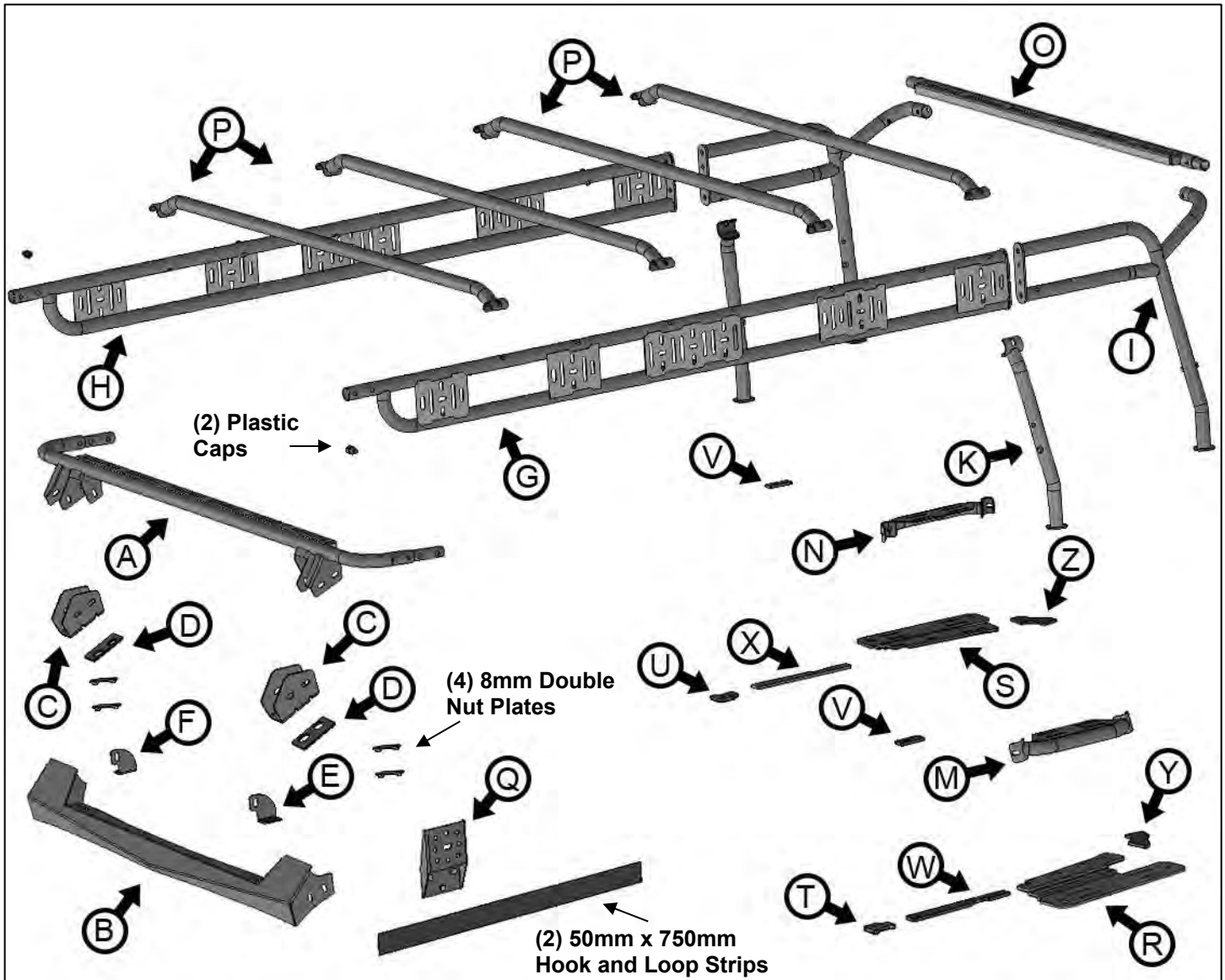

PROCEDURE:

REMOVE CONTENTS FROM BOX. VERIFY ALL PARTS ARE PRESENT. READ INSTRUCTIONS CAREFULLY. ASSISTANCE IS REQUIRED.

1. Hardtop models only, temporarily remove Freedom Top.
2. Determine if the vehicle is equipped with a factory accessory roof rack.

Hard Top models with roof rack

- a. Remove cover from top of roof rack mount, **(Figure 1)**.
- b. Remove tube nuts attaching end of roof rack, **(Figure 2)**. Repeat to remove remaining roof rack hardware and with assistance, remove entire roof rack rails.

Hard Top or Soft Top models without roof rack.

- a. Remove the plastic cover over the accessory mounting location, **(Figure 3)**.
 - b. Remove the inner bracket, **(Figure 4)**. Repeat **Steps** to remove the passenger/right cover and bracket.
3. Select (1) Front Mounting Bracket Shim, **(Figure 5)**, and (1) Front Mounting Bracket, **(Figure 6)**. Slide the Shim and the Bracket over the driver/left side mounting studs. Reuse the factory 6mm Flange Nuts or the (2) included 6mm Flange Nuts to attach the Shim and Bracket to the accessory mount studs, **(Figure 7)**. Do not fully tighten hardware at this time. Repeat this **Step** to attach the passenger/right side Shim and Mounting Bracket.

**TRAVELER ROOF RACK
2021-24 FORD BRONCO 4-DOOR**

4. Select the Front Crossbar. Attach the inner mounting plate on the Crossbar to the inner facing side of the driver/left Bracket with the included (1) 8mm x 30mm Hex Bolt, (2) 8mm x 24mm Large Flat Washers and (1) 8mm Nylon Lock Nut, **(Figure 8)**. Attach the outer mounting plate on the Crossbar to the inside of the Bracket with (2) 8mm x 30mm Hex Bolts, (2) 8mm Lock Washers, (2) 8mm x 24mm Large Flat Washers and (1) 8mm Double Nut Plate, **(Figure 9)**. Snug but do not fully tighten hardware at this time. Repeat this **Step** to attach the passenger/right side of the Crossbar to the Mounting Bracket.
5. Determine if vehicle is equipped with hard top or soft top.

Hard Top Models

- a. Remove hardware attaching top to inner roll bar and along the sides of the hard top to the body, (refer to owner's manual). With assistance, remove hard top. **NOTE:** Remove hard top or lift top up high enough and support hard top to install Seals, Spacers and Mounting Brackets.
- b. Select the lower hardtop driver/left front Spacer, **(Figure 10)**. Place Spacer over threaded hole in body and hole for alignment pin, **(Figures 11 & 14)**.
- c. Select the driver/left Mounting Bracket. Hold the Bracket in place over the threaded holes for the top hardware. Next, select the adhesive backed driver/left Top Side Seal, **(Figure 10)**. Remove the backing and attach the Top Seal to the body between the front Spacer and the Mounting Bracket, **(Figure 11)**. Do not attach Bracket at this time.
- d. Attach the adhesive backed driver/left Rear Top Seal to the top of the body, between the Mounting Bracket and the rear door opening, **(Figures 11—14)**.
- e. Repeat the previous **Steps** to attach the passenger/right front Spacer, Side and Rear Top Seal.
- f. Place the hard top assembly back in position on the vehicle but do not attach.
- g. With assistance, lift the driver/left side of the top up and insert the driver/left Mounting Bracket between the top and the body. Use the included (4) 8mm x 35mm Button Head Torx Bolts, (4) 8mm Lock Washers, (2) 8mm x 28mm X-Large Flat Washers and (2) 8mm x 20mm STD Flat Washers to attach the top, Bracket and front spacer, **(Figures 14 & 15)**. Leave hardware loose. Repeat to attach the passenger/right Bracket to the body and top.
- h. Next, insert (1) Top Spacer between the top bracket on the top and the inner roll bar, **(Figure 16)**. Reuse the factory bolt to attach the bracket and Spacer to the roll bar, **(Figure 17)**. Repeat this **Step** to insert (1) Spacer on the passenger/right side of the top.
- i. Align the top to the vehicle. Tighten the (2) top mounting bolts first, then tighten the bottom mounting bolts.
- j. Reinstall the Modular tops.

NOTE: If Modular top side latches are too tight/difficult to engage, slightly loosen the side latch Torx bolt on the handle until it becomes a snug fit. Repeat to adjust remaining latch, **(Figure 18)**

Soft Top models

- a. Temporarily remove the side and rear window panels, (refer to owner's manual).
 - b. Release the latches attaching the rear base on the top frame to the top of the body.
 - c. With assistance, lift up the rear top frame. Attach the driver/left Mounting Bracket to the threaded holes in the top of the body with the included (3) 8mm x 35mm Button Head Torx Bolts, (3) 8mm Lock Washers (1) 8mm x 20mm STD Flat Washer and (2) 8mm x 28mm X-Large Flat Washers, **(Figures 19 & 20)**. Leave hardware loose.
 - d. Attach the adhesive backed driver/left Rear Top Seal to the top of the body, between the Mounting Bracket and the rear door opening, **(Figure 21)**.
 - e. Repeat previous **Steps** to attach the passenger/right Bracket and rear Seal.
 - f. Latch top frame to body.
 - g. Reinstall the rear and side windows. Fasten windows to clips.
 - h. Attach the included wider double-sided hook and loop strip to the top of the side windows, **(Figure 22)**. **NOTE:** The wider hook and loop strip will help pull the side window up tighter in the opening.
 - i. Pull up slightly on side windows to remove sag and fasten to hook and loop strips and clips.
6. Select the driver/left Rear Corner Tube Assembly and driver/left Support Leg, **(Figure 23)**. Attach the Support Leg to the Corner Assembly with (1) 8mm x 50mm Button Head Bolt, (2) 8mm x 16mm Small

**TRAVELER ROOF RACK
2021-24 FORD BRONCO 4-DOOR**

Flat Washers and (1) 8mm Nylon Lock Nut, **(Figure 23)**. Next, attach the driver/left Corner Step to the two tubes with the included (2) 8mm x 50mm Button Head Bolts, (4) 8mm x 16mm Small Flat Washers and (2) 8mm Nylon Lock Nuts, **(Figure 24)**. **NOTE:** There are (2) sets of mounting holes to choose from for the Step, use the included (4) Plugs to seal off unused mounting holes. Repeat this **Step** to assemble the passenger/right Corner Assembly and Step.

7. Attach the Rear Crossbar Tube to the driver/left and passenger/right Rear Corner Assemblies with (2) 8mm x 50mm Button Head Bolts, (4) 8mm x 16mm Small Flat Washers and (2) 8mm Nylon Lock Nuts, **(Figure 25)**. Leave hardware loose at this time.
8. With assistance, carefully lift the rear Corner Assembly up and onto the rear Brackets. Do not slide the ends of the tubes on the Brackets to prevent damaging the finish. Attach the Rear Corner Assembly to the driver/left rear Bracket with the included (2) 10mm x 30mm Hex Bolts, (2) 10mm Lock Washers and (2) 10mm Flat Washers, **(Figure 26)**. Leave hardware loose at this time. Repeat this **Step** to attach the passenger/right side of the assembly.
9. Select the driver/left Side Rail. Attach the front of the Side Rail to the Front Loop with the included (2) 8mm x 50mm Button Head Bolts, (4) 8mm x 16mm Small Flat Washers and (2) 8mm Nylon Lock Nuts, **(Figure 27)**. **NOTE:** To clear the freedom top or soft top, insert Bolts from inside to outside. After Bolts have been fully tightened, cover Lock Nuts on end of Bolts with included Plastic Caps. Attach the rear of the Side Rail to the front of the Rear Corner Assembly with (2) 8mm x 30mm Button Head Bolts, (4) 8mm x 24mm Large Flat Washers and (2) 8mm Nylon Lock Nuts, **(Figure 28)**. Repeat this **Step** to attach the passenger/right Side Rail to the Front Loop and Rear Corner Assembly.
10. Select (1) Crossbar. Locate the mounting locations on the Side Rails for the crossbars. **NOTE:** Rack features multiple mounting locations, select the combination as desired. Attach each Crossbar to the top of the Side Rails with (2) 8mm x 50mm Button Head Bolts, (4) 8mm x 16mm Small Flat Washers and (2) 8mm Nylon Lock Nuts, **(Figure 29)**. Use the included Plugs to seal off unused mounting holes.
11. Check the Roof Rack for alignment, adjust as necessary and fully tighten all hardware.
12. Determine if Front Wind Fairing and LED bar style light, (light not included), will be installed.

Light installation on Fairing.

- a. Attach the driver/left and passenger/right LED “L” Brackets to the slots in the Wind Fairing first with the included (2) 8mm Combo Bolts and (2) 8mm Flange Nuts, **(Figure 30)**.
- b. Attach light to the “L” Brackets before installing Wind Fairing.

Wind Fairing installation.

- a. Attach the Wind Fairing to the outside of the Mounting Tabs on the Crossbar with the included (4) 8mm x 30mm Button Head Bolts, (4) 8mm Lock Washers, (4) 8mm x 24mm Large Flat Washers and (2) 8mm Double Nut Plates, **(Figure 31)**.
 - b. Align and adjust the Wind Fairing to fit the top of vehicle and fully tighten hardware.
13. Attach each Offset Accessory Mount to the Top Rail as desired with the included (3) 8mm Nylon Lock Nuts and (3) 8mm x 24mm Large Flat Washers. **(Figure 32)**.
 14. Do periodic inspections to the installation to make sure that all hardware is secure and tight.

To protect your investment, Do not use any type of polish or wax that may contain abrasives that could damage the finish. Mild soap may be used to clean the Roof Rack.

**TRAVELER ROOF RACK
2021-24 FORD BRONCO 4-DOOR**

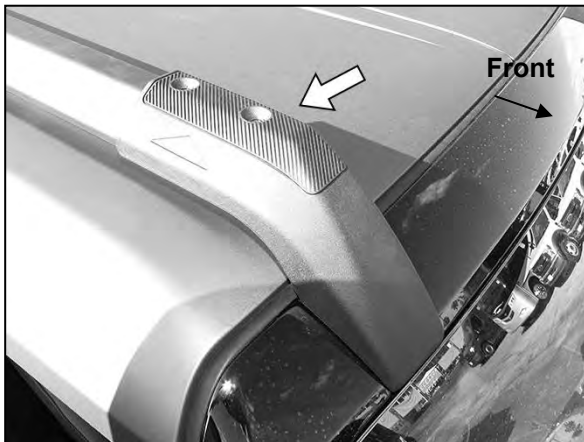

**(Fig 1) Models with factory roof rails,
remove cover to access mounting screws**

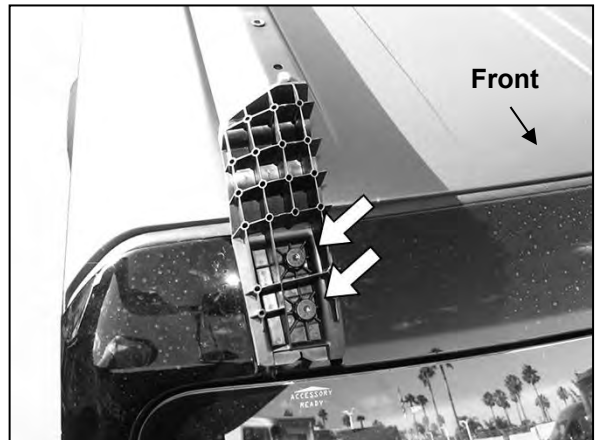

(Fig 2) Remove mounting hardware (arrows)



**(Fig 3) Models without factory roof rails,
remove cover and inner clip**

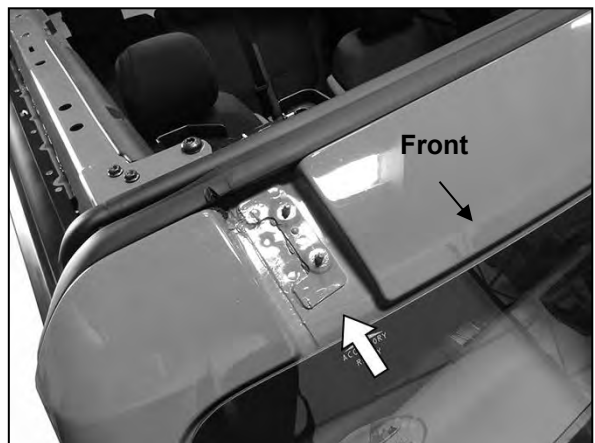

**(Fig 4) Passenger/right front
mounting location (arrow)**

**TRAVELER ROOF RACK
2021-24 FORD BRONCO 4-DOOR**



(Fig 5) Place Bracket Shim over threaded studs

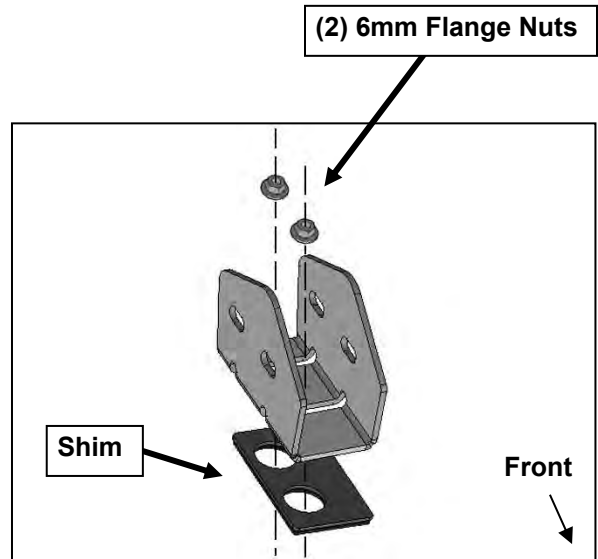

(Fig 6) Attach front crossbar Mounting Bracket to Shim and threaded studs. Driver/left side illustrated

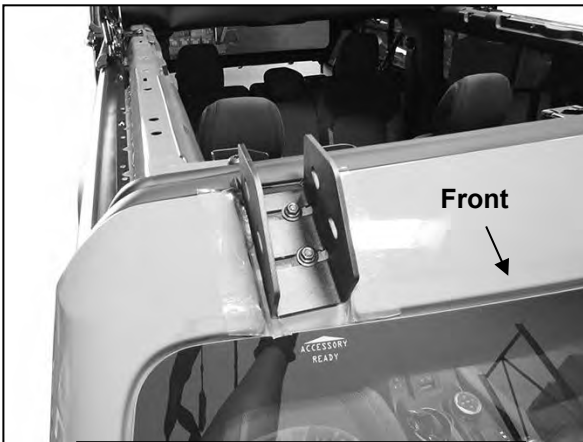

(Fig 7) Passenger/right side front Mounting Bracket installed

- 8mm x 30mm Hex Bolt
- (2) 8mm x 24mm Large Flat Washers
- 8mm Nylon Lock Nut

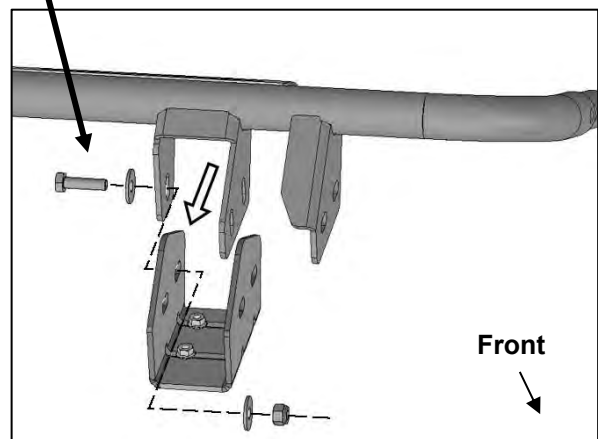

(Fig 8) Attach front Crossbar to side of Mounting Bracket (driver/left side illustrated)

Driver/left Side Installation Pictured

8mm Double
Nut Plate

(2) 8mm x 30mm Hex Bolts
(2) 8mm Lock Washers
(2) 8mm x 24mm Large Flat Washers

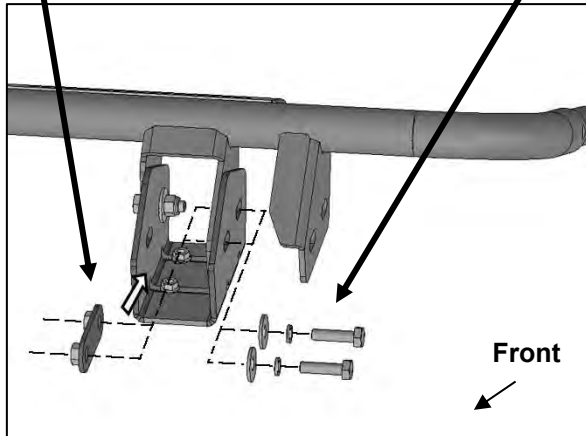

(Fig 9) Attach front Crossbar to inside of Mounting Bracket (driver/left side illustrated)

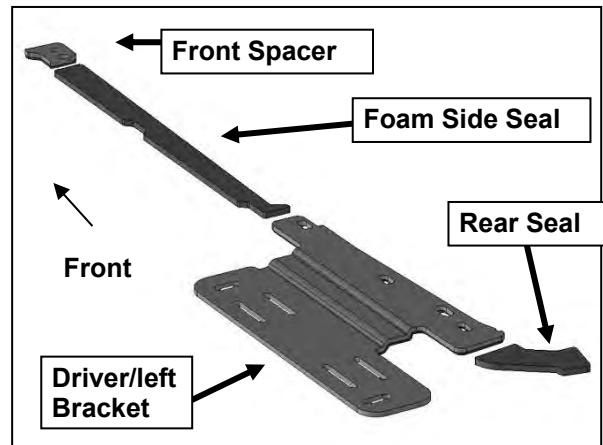

(Fig 10) Hard Top models only, remove hardware attaching roof. Temporarily remove or lift roof high enough to install Seals, Spacers and Brackets. Place Front Spacer over front threaded mounting hole (see Fig 14). Apply adhesive backed Foam Side Seal to top of body



(Fig 11) Remove backing and apply driver/left adhesive backed Foam Side Seal to top of body (arrows)



(Fig 12) Apply adhesive backed Foam Rear Seal to top of body

Driver/left Side Installation Pictured



(Fig 13) With Front Spacer, Seals and Bracket in place, reinstall top (driver/left side pictured)

- 8mm x 35mm Button Head TORX Bolt
- 8mm Lock Washer
- 8mm x 20mm STD Flat Washers

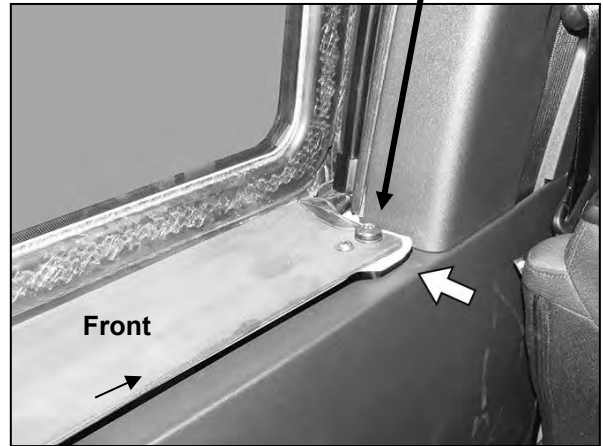

(Fig 14) Driver/left Front Spacer in place between top and body (arrow)

- (2) 8mm x 35mm Button Head TORX Bolts
- (2) 8mm Lock Washers
- (2) 8mm x 20mm STD Flat Washers

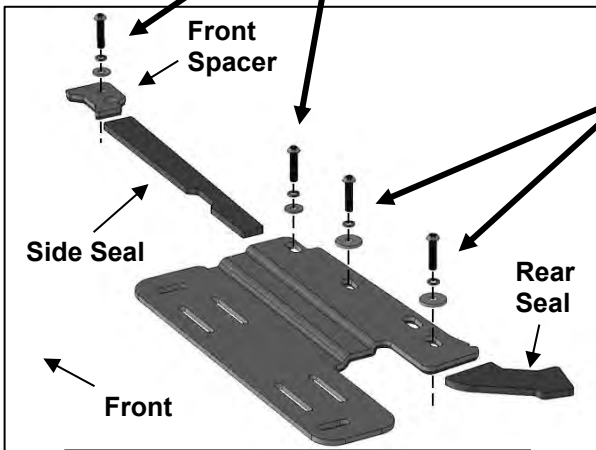

(Fig 15) Reinstall roof with Bracket between roof and body.

- (2) 8mm x 35mm Button Head TORX Bolts
- (2) 8mm Lock Washers
- (2) 8mm x 28mm X-Large Flat Washers

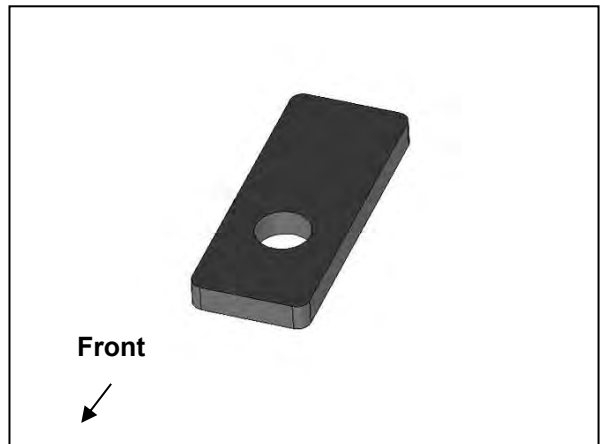

(Fig 16) Hard Top only Top Roof Spacer

Driver/left Side Installation Pictured

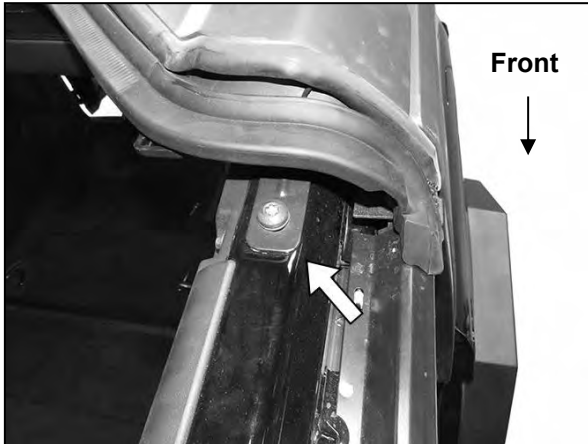

(Fig 17) Insert Top Roof Spacer between top bracket (arrow) and inner roll bar (driver/left side pictured)



(Fig 18) If necessary, loosen screw 2-3 turns to adjust and fasten latch (arrow)

- (1) 8mm x 35mm Button Head TORX Bolt
- (1) 8mm Lock Washer
- (1) 8mm x 20mm STD Flat Washers

- (2) 8mm x 35mm Button Head TORX Bolts
- (2) 8mm Lock Washers
- (2) 8mm x 28mm X-Large Flat Washers

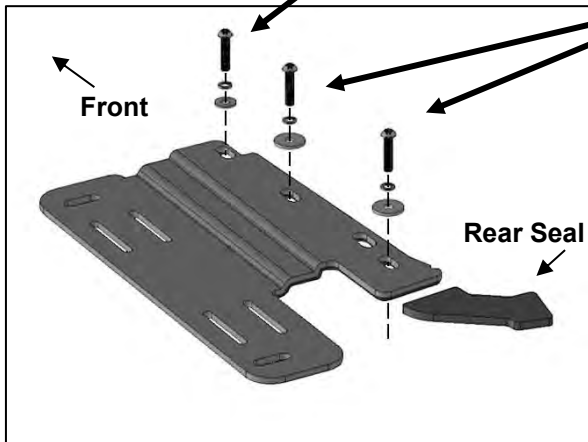

(Fig 19) Soft Top models only, remove side and rear windows. Release latches attaching rear or top frame. Lift top frame. Attach Roof Rack Mounting Brackets to threaded holes in top of body. Apply adhesive backed Foam Rear Seal to top of body, between top frame and body (driver/left side illustrated)

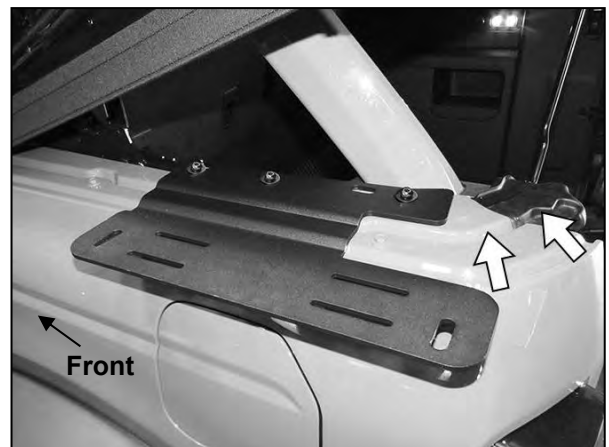

(Fig 20) Soft Top models only, Lift top frame. Attach Roof Rack Mounting Brackets to threaded holes in top of body. Apply adhesive backed Foam Rear Seal to top of body, between top frame and body (arrows)

Driver/left Side Installation Pictured



(Fig 21) Apply adhesive backed Foam Rear Seal to top of body, between top frame and body (driver/left side pictured)

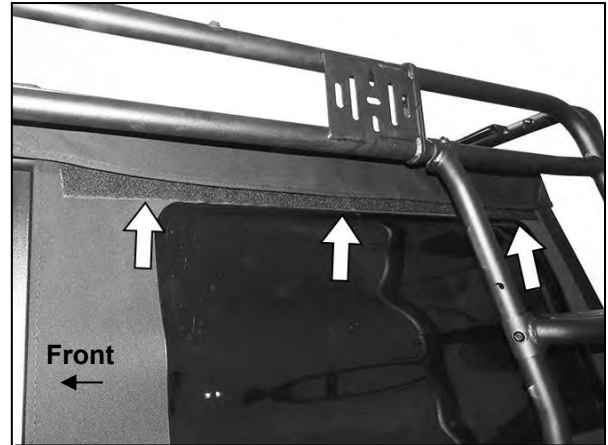

(Fig 22) Soft Top only, reinstall side and rear windows. Pull windows up tight and insert Hook and Loop Strip between top and side windows (arrows-driver/left side pictured after Roof Rack has been installed)

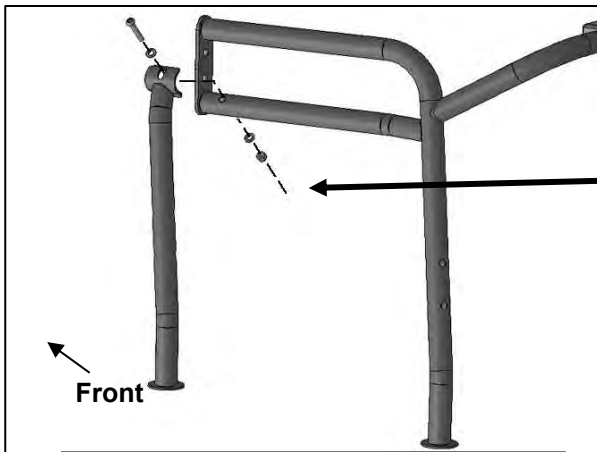

(Fig 23) Attach driver/left Support Leg to Corner Tube Assembly

8mm x 50mm Button Head Bolt
(2) 8mm x 16mm Small Flat Washers
8mm Nylon Lock Nut

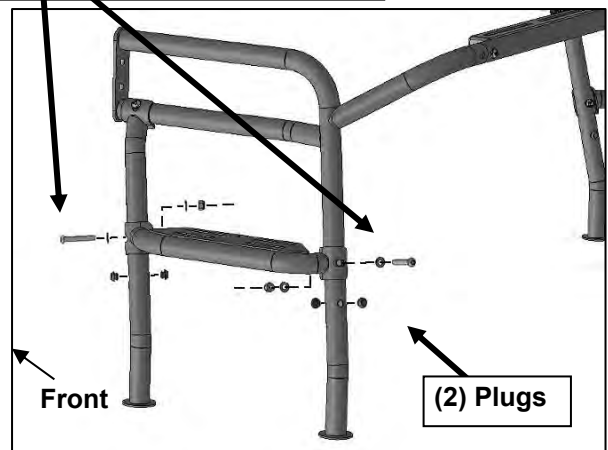

(Fig 24) Attach driver/left Ladder Step to either set of holes in Support Leg and Corner Tube Assembly

**TRAVELER ROOF RACK
2021-24 FORD BRONCO 4-DOOR**

- (1) 8mm x 50mm Button Head Bolt
- (2) 8mm x 16mm Small Flat Washers
- (1) 8mm Nylon Lock Nut

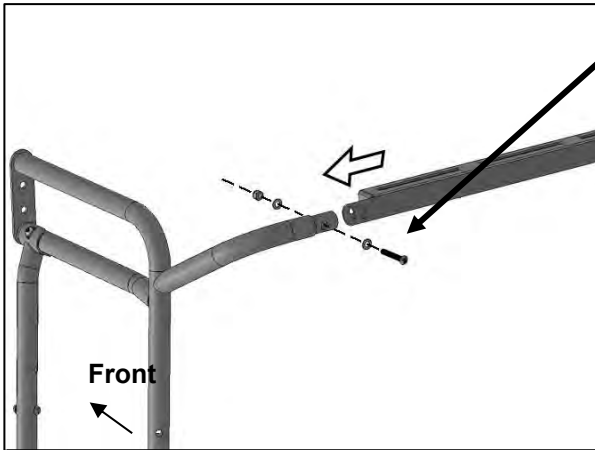

(Fig 25) Attach rear Cross Bar Tube to Corner Assembly. Place rear assembly onto Mounting Brackets

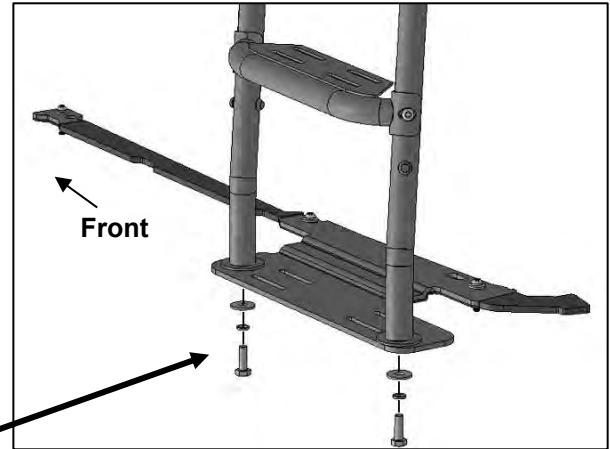

(Fig 26) Attach rear Rack Assembly to Mounting Brackets

- (2) 10mm x 30mm Hex Bolts
- (2) 10mm Lock Washers
- (2) 10mm Flat Washers

- (2) 8mm x 50mm Button Head Bolts
- (4) 8mm x 16mm Small Flat Washers
- (2) 8mm Nylon Lock Nuts
- (2) Plastic Caps

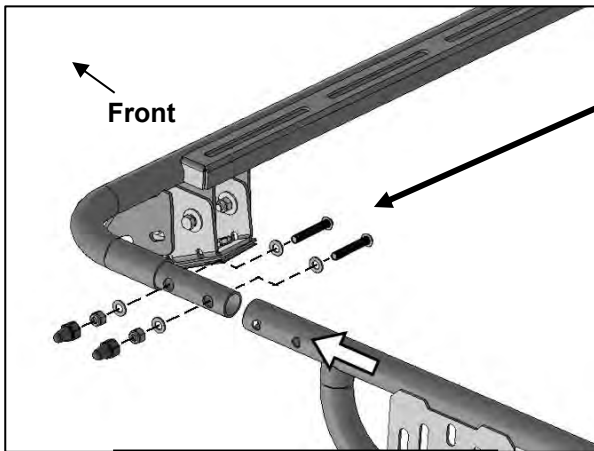

(Fig 27) Attach Side Rails to Front Crossbar Assembly

- (2) 8mm x 30mm Button Head Bolts
- (4) 8mm x 24mm Large Flat Washers
- (2) 8mm Nylon Lock Nuts

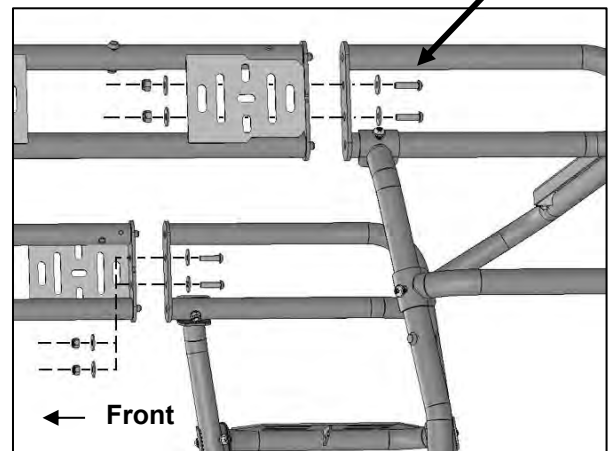

(Fig 28) Attach Side Rails to rear Rack Assembly

**TRAVELER ROOF RACK
2021-24 FORD BRONCO 4-DOOR**

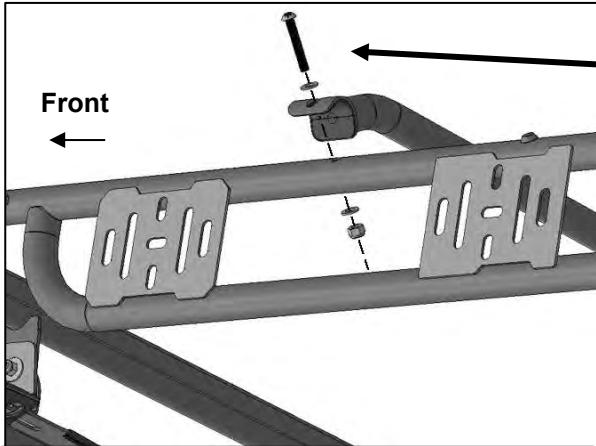

- (2) 8mm x 50mm Button Head Bolts
- (4) 8mm x 16mm Small Flat Washers
- (2) 8mm Nylon Lock Nuts
- or
- (2) Plugs

- 8mm x 16mm Hex Bolt
- 8mm Lock Washer
- 8mm x 24mm Large Flat Washer

- 8mm Combo Bolt
- 8mm Flange Nut

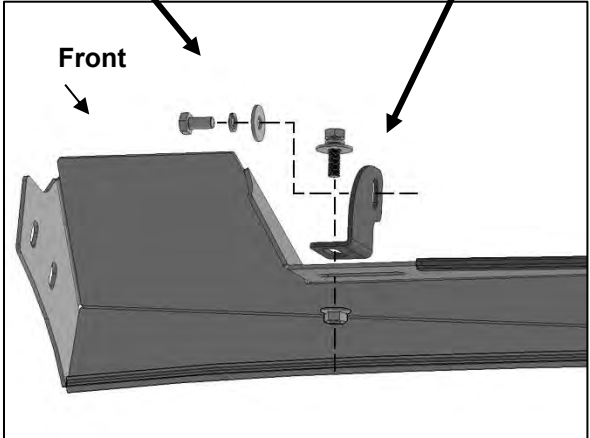

(Fig 30) Attach "L" Light Brackets to Wind Fairing (driver/left side illustrated)

(Fig 29) Attach remaining Cross Bars to desired mounting holes in Side Rails. Use the included Plugs to seal off any unused mounting holes, (driver/left side illustrated from below)

- 8mm Double Nut Plate

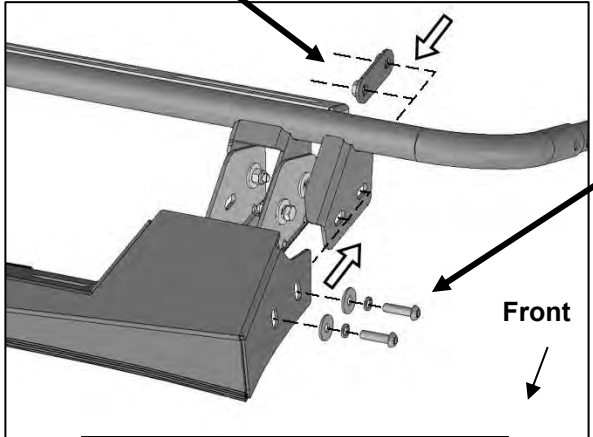

- (2) 8mm x 30mm Button Head Bolts
- (2) 8mm Lock Washers
- (2) 8mm x 24mm Large Flat Washers

(Fig 31) Attach Wind Fairing to outside of mounting tab

- (3) 8mm x 24mm Flat washers
- (3) 8mm Nylon Lock nuts

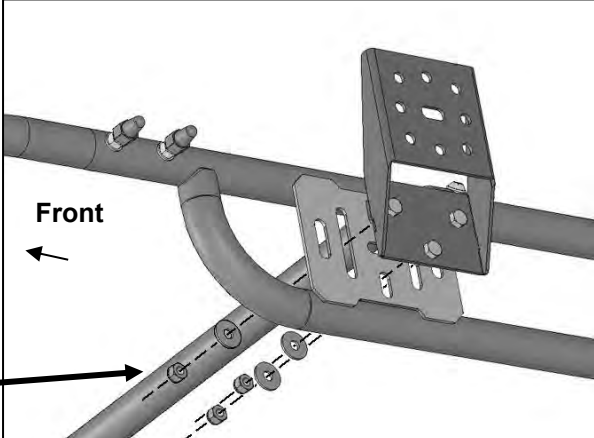

(Fig 32) Attach the Offset Accessory Mounts to the Side Rails as desired (driver/left side illustrated)