



**BLACK HORSE
OFF ROAD**

TEL: 1-866-XANATOS

INSTALLATION INSTRUCTIONS

**ARMOUR FRONT BUMPER FOR
14-15 CHEVY SILVERADO 1500
PART#AFB-SI14**

**LD1 FRONT BUMPER
2014-2015 CHEVY SILVERADO 1500**

PARTS LIST:

1	LD1 Front Bumper Assembly	6	12mm x 24mm OD x 2.5mm Flat Washers
1	Driver/left Frame Mounting Bracket	6	12mm Lock Washers
1	Passenger/right Frame Mounting Bracket	6	12mm Hex Nuts
2	Tow Hook Extension Brackets	6	10-1.5mm x 35mm Hex Bolts
4	Spacers (tow hooks)	12	10mm x 27mm OD x 3mm Flat Washers
1	License Plate Bracket	6	10mm Lock Washers
2	Plastic Plugs for License Plate	6	10mm Hex Nuts
4	Sensor Plugs	2	8mm x 16mm Hex Bolts
4	Sensor Retaining Clips	2	8mm x 25mm Hex Bolts
4	Sensor Sealing Washers	2	8mm Hex Nut
4	20mm x 2mm Foam Washers	4	8mm Lock Washer
1	GM Wire Harness Extension	6	8mm x 24mm x 2mm Flat Washers
1	Sensor Cover Kit	2	6mm x 20mm Button Head Bolts
1	Driver/left "L" Bracket (center LED light)	4	6mm x 18mm x 1.6 Flat Washers
1	Passenger/right "L" Bracket (center LED light)	2	6mm Nylon Lock Nuts
10	Nylon Wire Ties	1	6mm Wrench
2	12mm x 30mm Double Bolt Plates	8	4mm x 10mm Socket Head Screws
2	12mm x 35mm Single Bolt Plates	1	4mm Wrench

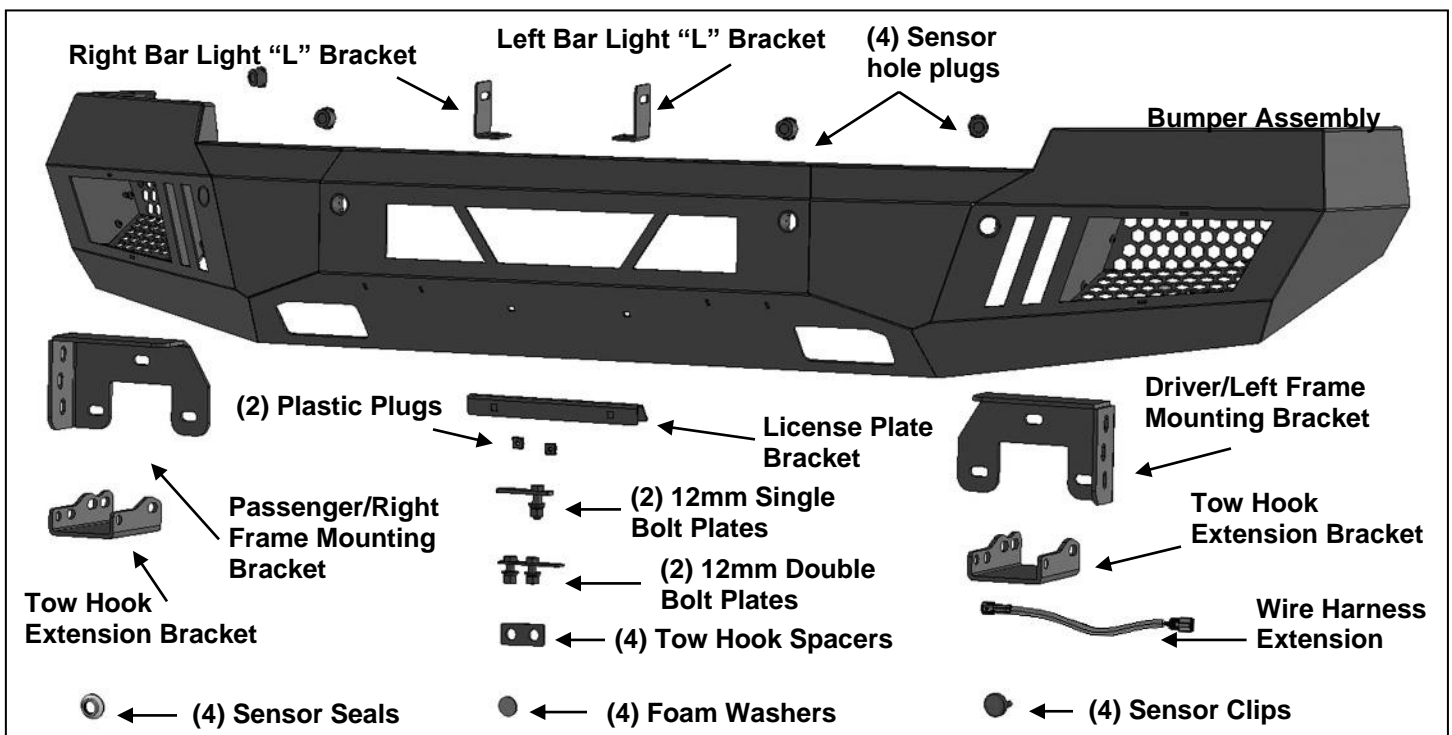

PROCEDURE:

REMOVE CONTENTS FROM BOX. VERIFY ALL PARTS ARE PRESENT. READ INSTRUCTIONS CAREFULLY BEFORE STARTING INSTALLATION. ASSISTANCE IS HIGHLY RECOMMENDED TO AVOID POSSIBLE INJURY OR DAMAGE TO THE VEHICLE.

1. Remove the license plate and bracket. On models with factory fog lights and/or bumper sensors, unplug the wiring harness leading to the bumper, **(Figure 1)**. Move harness away from bumper.
2. Next, locate and remove the screws attaching the ends of the plastic body panel, (facia), to the fenders. **NOTE:** Facia body panel fills the area between the headlights and the top of the bumper. From behind the bumper, release the clips attaching the facia body panel to the bottom of the grille and remove the panel. **(Figure 2)**.

**LD1 FRONT BUMPER
2014-2015 CHEVY SILVERADO 1500**

3. Open the hood and remove the cover between the top of the radiator and the grille, **(Figure 3)**. Remove the bolts attaching the top and bottom of the grille and remove the grille.
4. From behind the bumper, remove the outer bumper supports on each side of the frame.
5. Place blocks or jack stands under the front bumper to support it during mounting bolt removal. Once the bumper has been safely supported, from above, remove the (4) large factory bumper bolts, (two per side), attaching the bumper assembly to the frame bracket bolted to the end of the frame, **(Figure 4)**.
WARNING! Assistance is required to hold the bumper in place during bolt removal to prevent the bumper from falling. Carefully slide the bumper assembly with brackets off of the ends of the frame.
6. Once bumper has been removed, also remove the plastic brackets from the bottom of the headlight assemblies, **(Figure 5)**. Reinstall the grille and top cover removed in **Steps 2 & 3**.
7. Remove both bumper brackets and tow hooks from the ends of the frame, **(Figure 6)**.
8. Select the driver side Frame Mounting Bracket. Reuse the factory bumper bolts to attach the Frame Bracket to the threaded bumper mount, **(Figure 7)**. Do not fully tighten hardware at this time.
9. Repeat **Step 8** to install the passenger side Frame Bracket.

On models without tow hooks, skip to Step 13.

10. Next, select (1) Single Bolt Plate and (1) Double Bolt Plate, **(Figure 8)**. Insert the Bolt Plates into the open end of the frame, with the long end on the plate in first toward the back. Select (1) Tow Hook Extension Bracket. Slide the Bracket over the end of the frame. Line up the slots in the Bracket with the factory tow hook mounting holes. Secure the Bracket to the Bolt Plates with (3) 12mm Flat Washers, (3) 12mm Lock Washers and (3) 12mm Hex Nuts, **(Figure 9)**. Leave loose at this time.
11. Select (1) tow hook. Place the tow hook on top of the Extension Bracket. Slide (1) Spacer Plate between each side of the tow hook and the Bracket. Reuse the factory hardware to attach the tow hook to the Extension Bracket, **(Figure 10)**. Push the tow hook, spacers and Extension Bracket in and fully tighten tow hook and extension bracket hardware only. Do not tighten Frame Bracket hardware.
12. Repeat **Steps 10 & 11** to install the passenger side Extension Bracket and tow hook if equipped.
13. Determine if the vehicle is equipped front sensors:

Models without bumper sensors:

- a. Select the included (4) Rubber Plugs.
- b. From behind bumper, push plugs into sensor mounting holes, **(Figure 11)**. Screws have been provided to lock the plugs in the sleeve. Use is optional.

Models with bumper mounted sensors:

- a. Unplug and remove sensors and wiring harness from factory bumper. Test fit sensor in sleeve. It may be necessary to cut or grind off the tabs on the sides of the sensor to fit into the sleeve.
 - b. Remove the silicone seal from the end of the sensor. Slide the included larger Sensor Seal over front of sensor, **(Figure 12)**.
 - c. Insert sensor with Seal into sensor mount, **(Figure 13)**.
 - d. Place Foam Washer over end of sensor. Push Sensor Retaining Clip into sensor mount and lock into mounting holes, **(Figure 13)**.
 - e. Repeat previous Steps to install remaining sensors.
 - f. Install wiring harness for sensors. **NOTE:** A Wire Harness Extension has been included to extend the factory harness to a sensor as needed. Use is optional.
 - g. **Optional:** Secure each sensor to the socket with (2) 4mm x 10mm Button Head Screws, **(Figure 11)**. **IMPORTANT:** Sensors fit snug in sockets. The 4mm Screws are used to apply slight pressure to lock the sensors in place. Tighten both screws evenly until they touch the sensor body only. Do not overtighten screws or damage to sensors will result.
14. If front license plate is required, attach the License Plate Bracket to the holes in the bumper with the included (2) 6mm x 20mm Button Head Screws, (4) 6mm Flat Washers and (2) 6mm Nylon Lock Nuts. Insert (2) Plastic Plugs into the square holes in the Bracket. Reuse the factory screws to attach the license plate to the plastic plugs, **(Figure 14)**.
 15. **Center LED light installation** as supplied with bumper or sold separately.
 - a. Select the L/R "L" Brackets, **(Figure 15)**. Attach the Brackets to the top of the (2) mounting tabs welded onto the back of the bumper with the included 8mm x 25mm Hex Bolts, (4) 8mm Flat Washers, (2) 8mm Lock Washers and (2) 8mm Hex Nuts. Leave loose at this time.

**LD1 FRONT BUMPER
2014-2015 CHEVY SILVERADO 1500**

- b. Attach the LED light assembly to the “L” Brackets with the included (2) 8mm x 16mm Hex Bolts, (2) 8mm Lock Washers and (2) 8mm Flat Washers. Do not fully tighten hardware at this time.
IMPORTANT: “L” Brackets are designed for 8mm light mounting hardware only. Modify “L” Brackets if necessary or use brackets supplied by your light manufacturer if possible, to install hardware larger than 8mm.
 - c. Follow light manufacturer’s instructions to properly wire the light.
- 16. LED light installation at ends of bumper** as supplied with bumper or sold separately.
- a. Insert light into opening and up to mounting slots. Check for clearance between front and back of light. If necessary, remove the screen from the back of the opening, **(Figure 16)**.
 - b. Follow the light manufacturer’s instructions to attach (1) light to the center slot or (2) lights to the inner and outer slots in the top of the light opening. **IMPORTANT:** On two light systems with (1) flood and (1) spot light per side, attach the flood light to the outer and the spot light to the inner slot.
 - c. Repeat the above steps for passenger side light installation.
 - d. Follow light manufacturer’s instructions to properly wire the light.
- 17.** With assistance, position the Bumper Assembly up to and over the Frame Brackets. Temporarily support the weight of the Bumper. **WARNING:** To avoid possible injury or damage to the vehicle, do not proceed until the Bumper is fully and safely supported.
- 18.** Line up the (3) holes in the driver side mounting plate on the back of the Bumper with the (3) slots in the Frame Bracket. Attach the Bumper to the Bracket with the included (3) 10mm x 35mm Hex Bolts, (6) 10mm Flat Washers, (3) 10mm Lock Washers and (3) 10mm Hex Nuts, **(Figures 17 & 18)**. Do not fully tighten hardware at this time. Repeat this **Step** to attach the passenger side of the Bumper.
- 19.** Level and adjust the bumper and fully tighten all hardware. Reattach wiring harness if equipped.
- 20.** Do periodic inspections to the installation to make sure that all hardware is secure and tight.

To protect your investment, wax this product after installing. Regular waxing is recommended to add a protective layer over the finish. Do not use any type of polish or wax that may contain abrasives that could damage the finish. Mild soap may be used to clean the Front Bumper assembly.

Driver Side Installation Pictured

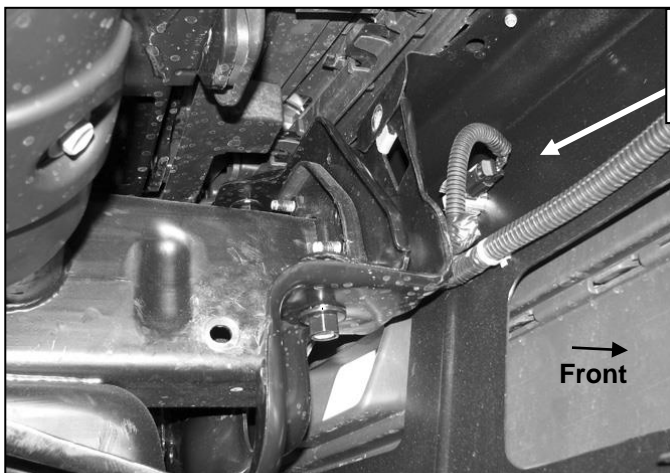

(Fig 1) Unplug sensors, fog lights and move wiring harness away from bumper before removal



(Fig 2) From behind bumper, release clips along the center and the hardware at the fenders attaching the plastic fascia panel (arrow) to top of bumper. Remove fascia panel to access bumper hardware

Driver Side Installation Pictured

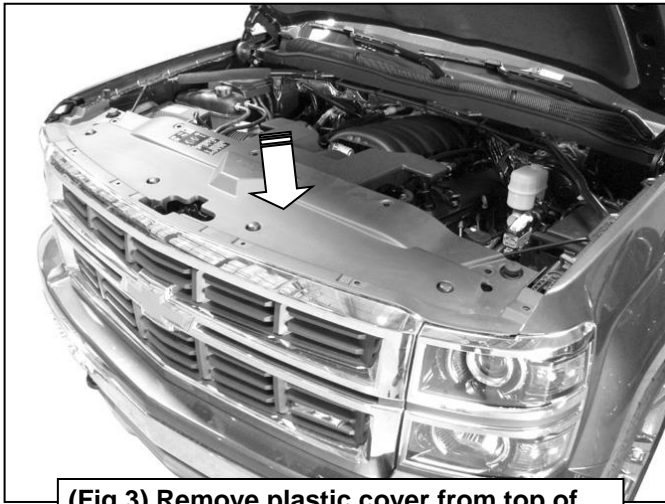

(Fig 3) Remove plastic cover from top of radiator (arrow). Temporarily remove grille

WARNING! Do not crawl under bumper unless the bumper is properly supported on blocks or stands or the bumper may fall.

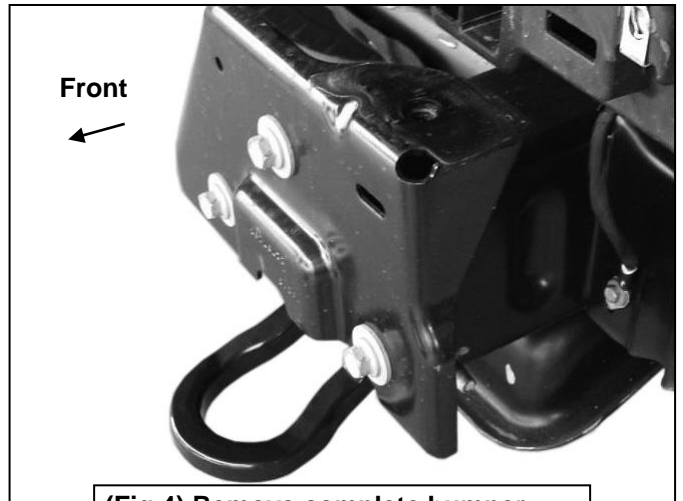

(Fig 4) Remove complete bumper, inner bumper bracket and tow hooks

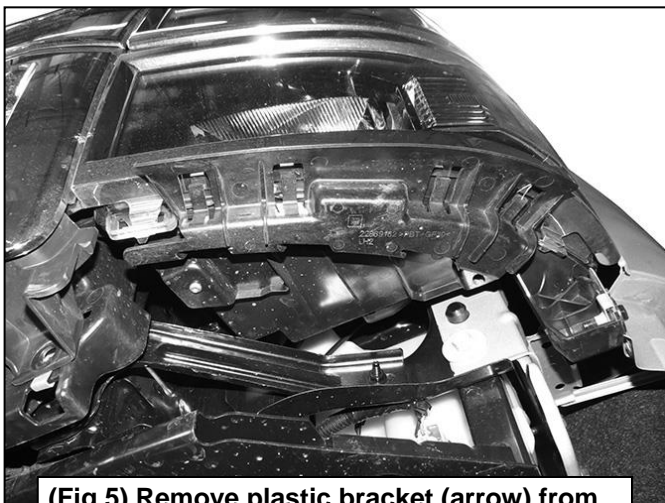

(Fig 5) Remove plastic bracket (arrow) from bottom of headlight (driver/left side pictured)

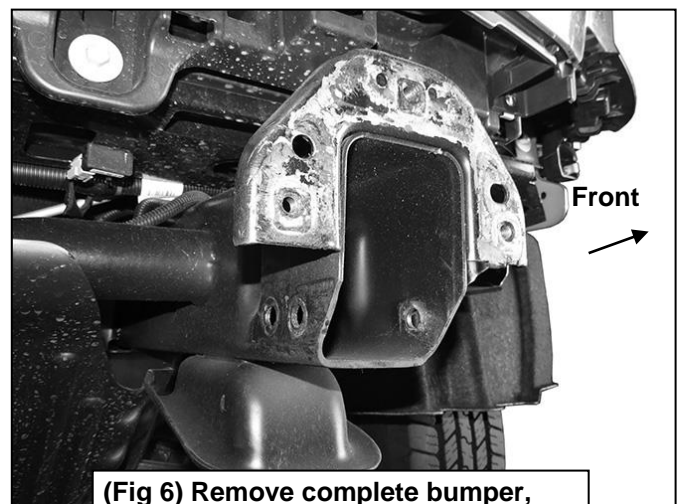

(Fig 6) Remove complete bumper, inner bumper bracket and tow hooks

Driver Side Installation Pictured

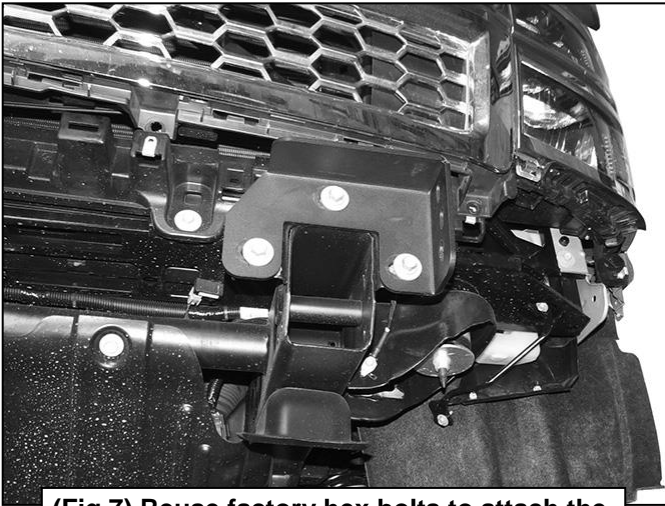

(Fig 7) Reuse factory hex bolts to attach the driver/left Frame Bracket to frame mount

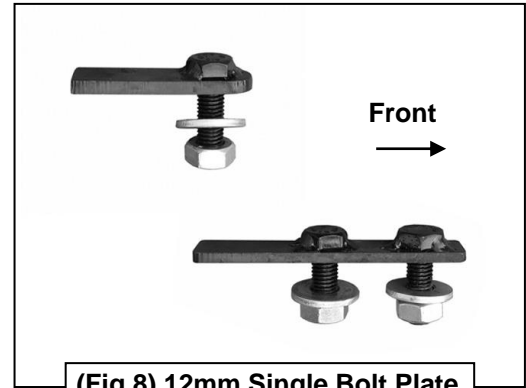

(Fig 8) 12mm Single Bolt Plate and 12mm Double Bolt Plate

- Double Bolt Plate**
(2) 12mm Flat Washers
(2) 12mm Lock Washers
(2) 12mm Hex Nuts

- Single Bolt Plate**
12mm Flat Washer
12mm Lock Washer
12mm Hex Nut

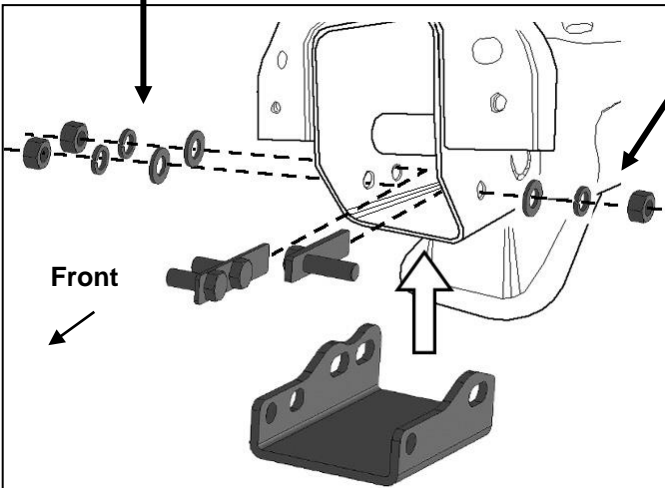

(Fig 9) Insert long end on Bolt Plates into open end of frame first then attach the Tow Hook Bracket (if equipped) to the frame and Bolt Plates

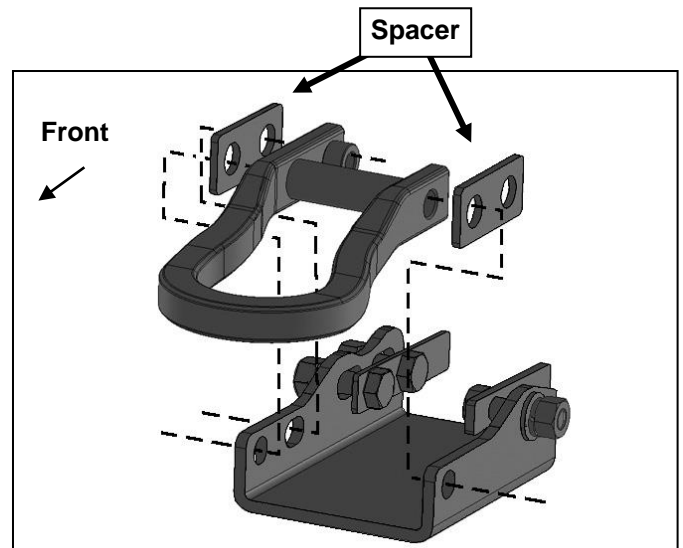

(Fig 10) Slide Spacer between each side of tow hook. Attach tow hook to Bracket with factory hardware.

Driver Side Installation Pictured

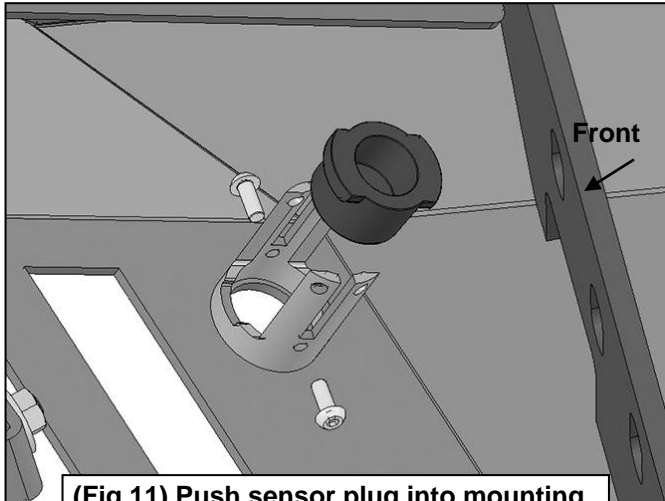

(Fig 11) Push sensor plug into mounting sleeve. Use of 4mm Screws is optional

NOTE: Sensor plugs fit snug in sockets. Use of the 4mm Screws is optional. 4mm Screws can also be used to apply slight pressure to lock the sensors in place or to aim the sensor. Tighten both screws evenly until they touch the sensor body only. Do not overtighten screws or damage to sensors will result.

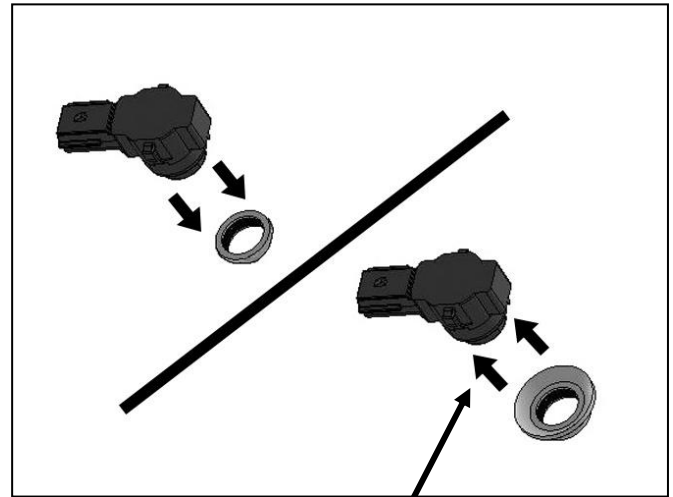

(Fig 12) Remove silicone seal from sensor. Slide large Seal over end of sensor (arrow)

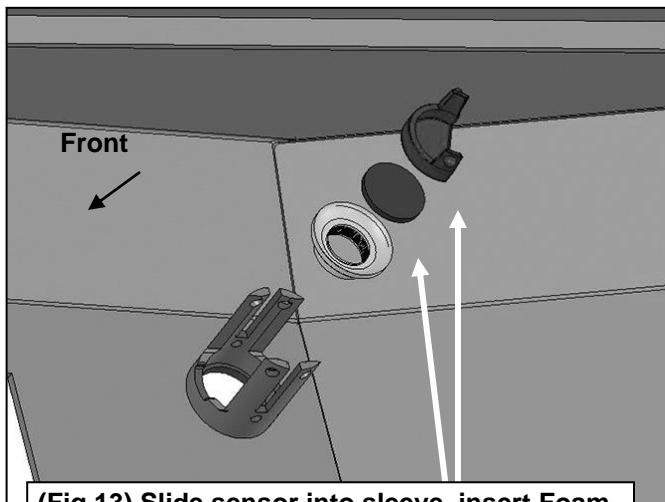

(Fig 13) Slide sensor into sleeve, insert Foam Washer and Clip to lock sensor in sleeve

- (2) 6mm x 20mm Button Head Screws
- (4) 6mm Flat Washers
- (2) 6mm Nylon Lock Nuts

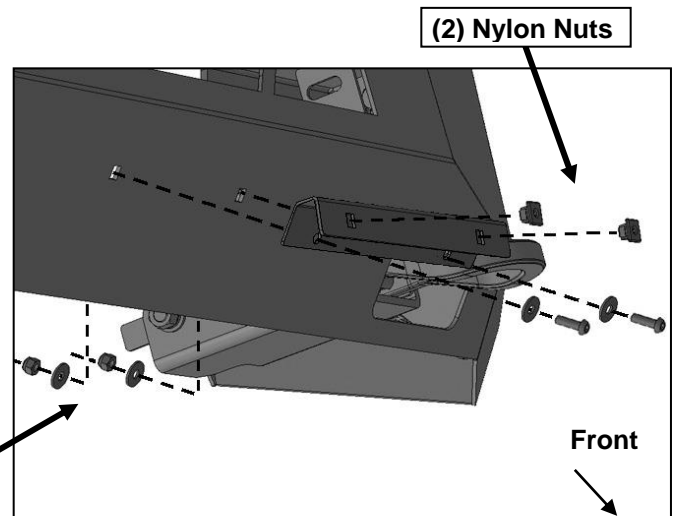

(Fig 14) Attach License Plate Bracket to Bumper

Driver Side Installation Pictured

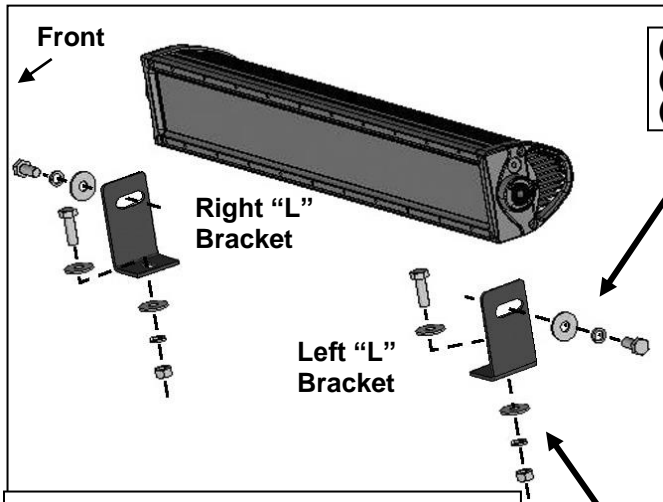

- (2) 8mm x 16mm Hex Bolts
- (2) 8mm Lock Washers
- (2) 8mm Flat Washers

(Fig 15) Typical center light installation

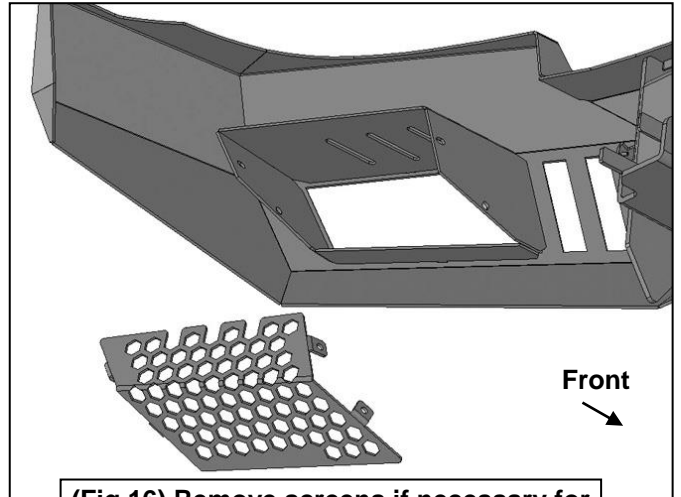

- (2) 8mm x 25mm Hex Bolts
- (4) 8mm Flat Washers
- (2) 8mm Lock Washers
- (2) 8mm Hex Nuts

(Fig 16) Remove screens if necessary for clearance/access to outer light mounts

- (3) 10mm x 35mm Hex Bolts
- (6) 10mm Flat Washers
- (3) 10mm Lock Washers
- (3) 10mm Hex Nuts

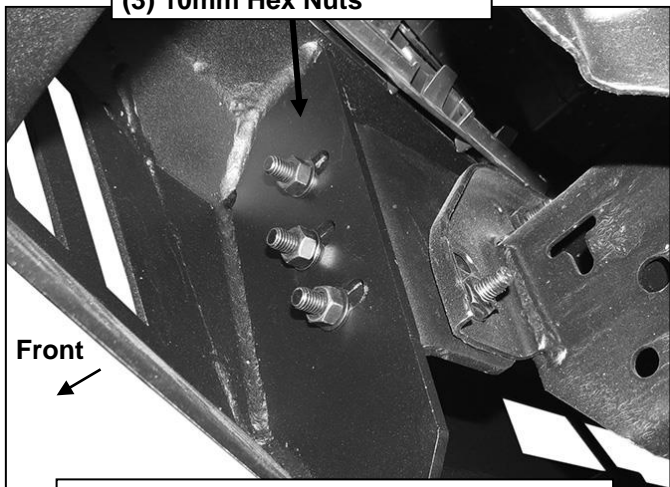

(Fig 17) Attach Bumper to Frame Brackets

WARNING! Do not crawl under bumper unless the bumper is properly supported on blocks or stands or the bumper may fall.

- (3) 10mm x 35mm Hex Bolts
- (6) 10mm Flat Washers
- (3) 10mm Lock Washers
- (3) 10mm Hex Nuts

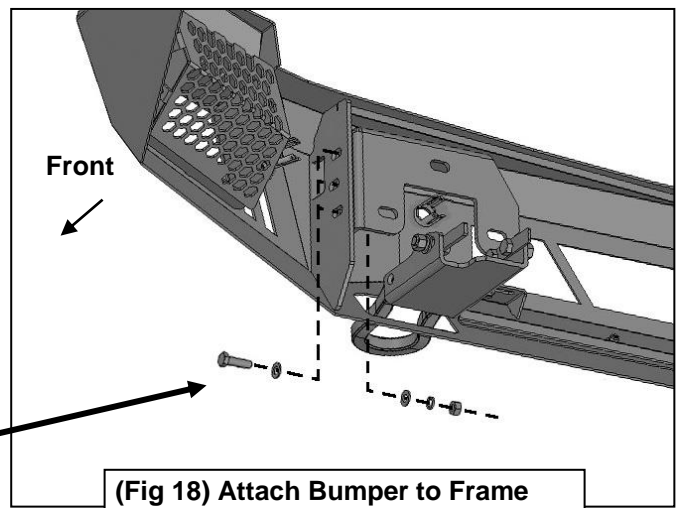

(Fig 18) Attach Bumper to Frame Brackets. Driver/left side illustrated