



**BLACK HORSE
OFF ROAD®**

TEL: 1-866-XANATOS

INSTALLATION INSTRUCTIONS

**ARMOUR III LD FRONT BUMPER
15-20 CHEVY COLORADO (Excl. ZR2)
PART# AR3LD01NL**

**CS1 LD FRONT BUMPER
2015-20 CHEVY COLORADO
(EXCLUDES DIESEL, ZR2 MODELS)**

PARTS LIST:

| | | | |
|---|---------------------------------------|----|------------------------------------|
| 1 | CS1 Front Bumper | 6 | 12-1.75mm x 40mm Hex Bolts |
| 1 | Driver/left Frame Bracket | 6 | 12mm x 37mm x 3mm Flat Washers |
| 1 | Passenger/right Frame Bracket | 16 | 12mm x 24mm x 2.5mm Flat Washers |
| 1 | Driver/left Top Light "L" Bracket | 6 | 12mm Lock Washer |
| 1 | Passenger/right Top Light "L" Bracket | 8 | 12mm Nylon lock Nuts |
| 1 | Center Mesh Fill Panel | 8 | 8-1.25mm x 25mm Hex Bolts |
| 1 | Driver/left Mesh Fill Panel | 2 | 8-1.25mm x 16mm Hex Bolts |
| 1 | Passenger/right Mesh Fill Panel | 18 | 8mm x 24mm x 2mm Flat Washers |
| 2 | Center "L" Brackets | 10 | 8mm Lock Washers |
| 1 | License Plate Bracket | 8 | 8mm Hex Nuts |
| 2 | Plastic Plugs for License Plate | 8 | 6mm x 20mm Button Head Combo Bolts |
| 2 | 12mm Triple Nut Plates | 1 | 4mm Wrench |
| 4 | 12-1.75mm x 110mm Hex Bolts | 10 | Nylon Wire Ties |
| 4 | 12-1.75mm x 90mm Hex Bolts | | |

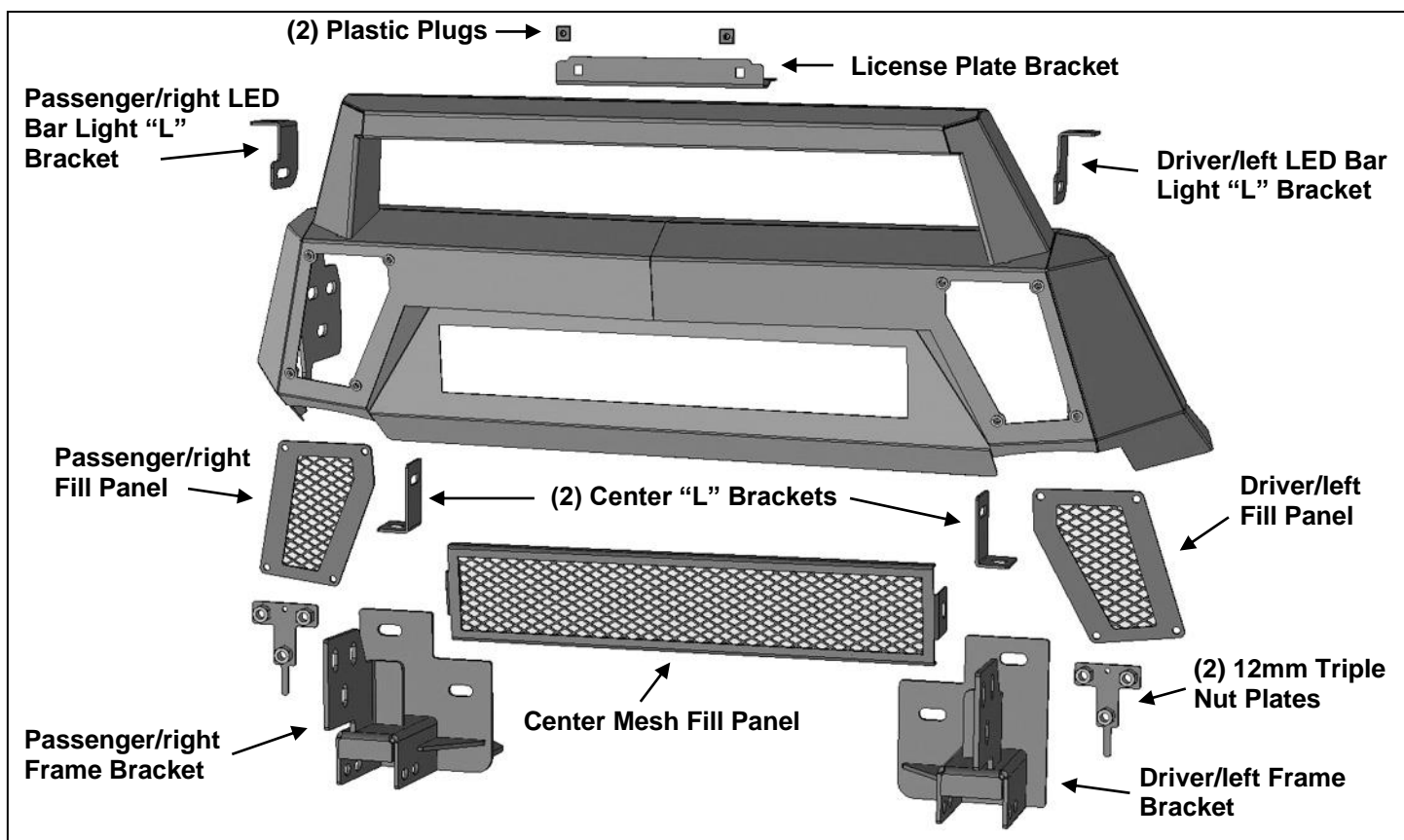

PROCEDURE:

REMOVE CONTENTS FROM BOX. VERIFY ALL PARTS ARE PRESENT. READ INSTRUCTIONS CAREFULLY BEFORE STARTING INSTALLATION. ASSISTANCE IS RECOMMENDED TO AVOID POSSIBLE INJURY OR DAMAGE TO THE VEHICLE.

1. Remove the license plate and bracket. Next, open the hood and remove the hex bolts attaching the plastic cover to the top of the radiator and the grille, **(Figure 1)**.
2. Move to below the front bumper and remove the plastic inner cover below the radiator, **(Figure 2)**. Remove the hex bolt attaching the bottom of the bumper cover to the steel inner impact bumper, **(Figure 3)**. Next, locate the driver/left side plastic inner bumper reinforcement. Remove the hardware attaching the reinforcement to the end of the frame, **(Figure 4)**.

**CS1 LD FRONT BUMPER
2015-20 CHEVY COLORADO
(EXCLUDES DIESEL, ZR2 MODELS)**

3. Move to the driver/left side wheel opening and remove the (7) screws attaching the plastic fender liner to the fender, **(Figure 5)**. Pull back the liner from the fender. Reach in through the opening to locate and remove the (3) screws attaching the end of the bumper cover to the front of the fender just the outside of the headlight, **(Figure 6)**. On models with factory fog lights, unplug the wiring harness leading to the light, **(Figure 7)**. Move harness away from bumper.
 4. Repeat **Steps 2 & 3** to remove the bumper cover hardware from the passenger/right side of the vehicle.
 5. With assistance, gently pull the bumper cover with grille attached, outward from the vehicle, **(Figure 8)**.
 6. From the front, locate and remove the air deflector, **(Figure 8)**.
 7. Remove tow hooks if equipped.
 8. Remove the (2) hex bolts attaching the driver/left side of the steel impact bumper to the end of the frame, **(Figure 9)**.
 9. Select the driver/left Frame Mounting Bracket, **(Figure 10)**. Slide the Bracket between the impact bumper and the end of the frame. Reuse the (2) factory hex bolts to reattach the impact bumper. Leave hardware loose.
 10. Attach the bottom mount on the Frame Bracket to the tow hook mount on the bottom of the frame with the included (2) 12mm x 90mm Hex Bolts, (4) 12mm x 24mm STD Flat Washers, (2) 12mm Lock Washers and (2) 12mm Hex Nuts, **(Figures 11 & 12)**.
 11. Repeat **Steps 8—10** to attach the passenger/right Frame Bracket.
 12. Carefully unwrap the CS1 Front Bumper. Hold the CS1 Bumper up to the Brackets to check alignment of Brackets to Bumper. Check alignment of Bumper to vehicle, adjust Brackets as necessary and fully tighten Bracket to frame hardware.
 13. Next, move to the back of the factory plastic bumper, **(Figure 13)**. Remove the outer bumper reinforcements. Remove the air dam from the bottom of the bumper. Remove the lower grille from the bumper, **(Figure 14)**. Reinstall the outer plastic reinforcements. Reinstall the bumper, **(Figure 15)**.
 14. Determine if accessory lights, (not included), or Screen Fill Panels will be installed at this time.
IMPORTANT: It may be easier to install Center Fill Panels and/or lights before installing Bumper.
- Inner Screen Fill Panel Installation (do not install Center Fill Panel if installing light).**
- a. Select (1) "L" Light Bar Bracket, **(Figure 16)**.
 - b. Attach the "L" Bracket to the slot on the back of the driver/left side of the Bumper with (1) 8mm x 25mm Hex Bolt, (2) 8mm Flat Washers, (1) 8mm Lock Washer and (1) 8mm Hex Nut, **(Figure 16)**. Repeat this **Step** to attach the "L" Bracket to the passenger/right side of the Bumper. Leave hardware loose.
 - c. Select the center Screen Fill Panel, **(Figure 16)**.
 - d. Attach the Screen to the "L" Brackets with the included (2) 8mm x 25mm Hex Bolts, (4) 8mm Flat Washers, (2) 8mm Lock Washers and (2) 8mm Hex Nuts, **(Figure 16)**. Do not fully tighten hardware at this time.
 - e. Push the Screen up against the back of the Bumper and fully tighten Fill Panel hardware only.
- Inner center LED bar style light installation, (light not included-do not install Mesh Panel with light).**
- a. Select (1) "L" Light Bar Bracket, **(Figure 17)**.
 - b. Attach the "L" Bracket to the slot on the back of the driver/left side of the Bumper with (1) 8mm x 25mm Hex Bolt, (2) 8mm Flat Washers, (1) 8mm Lock Washer and (1) 8mm Hex Nut, **(Figure 17)**. Repeat this Step to attach the "L" Bracket to the passenger/right side of the Bumper.
 - c. Attach the light to the "L" Brackets with the hardware included with the light or the supplied (2) 8mm x 16mm Hex Bolts, (2) 8mm Lock Washers and (2) 8mm Flat Washers, **(Figure 17)**. Adjust and fully tighten light and "L" bracket hardware only at this time.
15. With assistance, position the Bumper Assembly up to the outside of the Brackets. **WARNING:** To avoid possible injury or damage to the vehicle, do not proceed until the Bumper is fully and safely supported.
 16. Line up the (3) holes in the driver/left side mounting plate on the back of the Bumper with the (3) slots in the Bracket. Insert (1) 12mm Triple Nut Plate through the opening in the bottom of the Bumper, **(Figure 18)**. Attach the Bumper to the Bracket and Nut Plate with the included (3) 12mm x 40mm Hex Bolts, (3) 12mm Lock Washers, and (3) 12mm Large Flat Washers, **(Figures 18 & 19)**. Do not fully tighten hardware. Repeat this **Step** to attach the passenger/right side of the Bumper to the Bracket.

**CS1 LD FRONT BUMPER
2015-20 CHEVY COLORADO
(EXCLUDES DIESEL, ZR2 MODELS)**

17. Align the CS1 Bumper to the factory bumper cover and adjust as necessary. Once properly fit, fully tighten all hardware. If necessary, temporarily remove the CS1 Bumper to access all Bracket mounting hardware. Once fully tightened, reinstall the CS1 Bumper and fully tighten hardware.
18. Models with tow hooks, attach tow hooks to mounts on bottom of Frame Brackets with the included (4) 12mm x 110mm Hex Bolts, (8) 12mm x 24mm STD Flat Washers, (4) 12mm Lock Washers and (4) 12mm Hex Nuts **(Figures 11 & 20)**. Fully tighten hardware.
19. **Top LED light installation (optional, light not included)**. Select (1) "L" Light Bracket, **(Figure 21)**. Use the provided (1) 8mm x 25mm Hex Bolt, (2) 8mm Flat Washers, (1) 8mm Lock Washer and (1) 8mm Hex Nut to attach the "L" Bracket to the mounting tab. Repeat to install the driver/left Bracket. Follow instructions packaged with light to attach light to Brackets.
20. Models requiring front license plate, attach the included License Plate Bracket to the top of the hoop with the included (2) 8mm x 25mm Hex Bolts, (4) 8mm Flat Washers, (2) 8mm Lock Washers and (2) 8mm Hex Nuts, **(Figure 22)**. Insert (2) Plastic Plugs into the square holes in the License Plate Bracket for license plate.
21. Attach the Mesh Fill Panels to the Bumper with the included (8) 6mm x 20mm Button Head Combo Bolts, **(Figure 23)**. Installation is optional.
22. Do periodic inspections to the installation to make sure that all hardware is secure and tight.

To protect your investment, Do not use any type of polish or wax that may contain abrasives that could damage the finish. Mild soap may be used to clean the Bumper assembly.

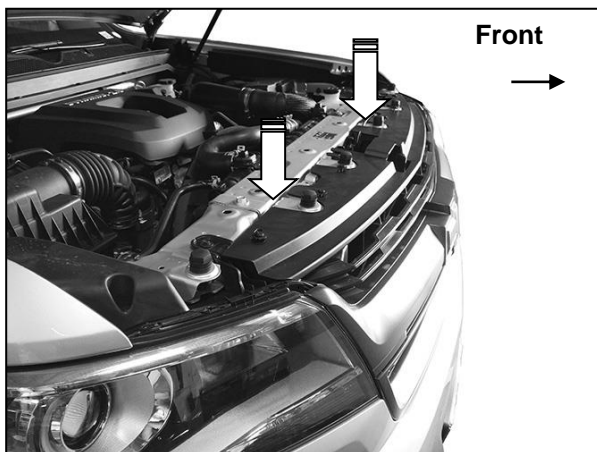

(Fig 1) Remove cover between radiator and grille. Remove screws attaching top of grille (arrows)

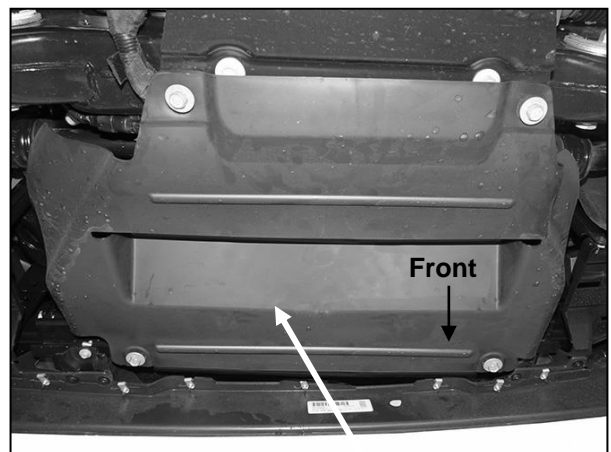

(Fig 2) Remove splash guard or skid plate from bottom of engine behind bumper

**CS1 LD FRONT BUMPER
2015-20 CHEVY COLORADO
(EXCLUDES DIESEL, ZR2 MODELS)**

Driver/left Side Installation Pictured

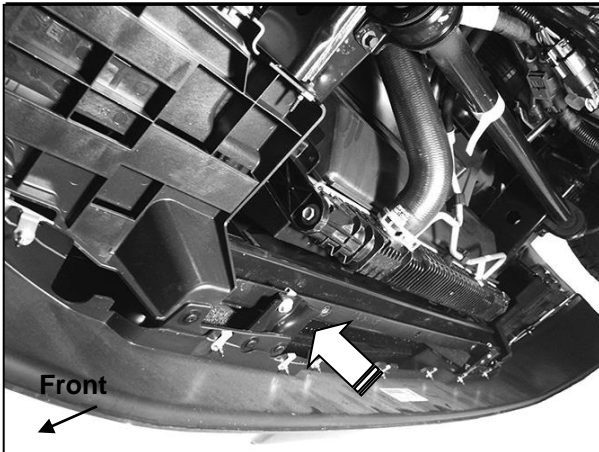

(Fig 3) Remove hardware attaching bumper cover to cross member behind bumper, (arrow). Driver/left side pictured from below

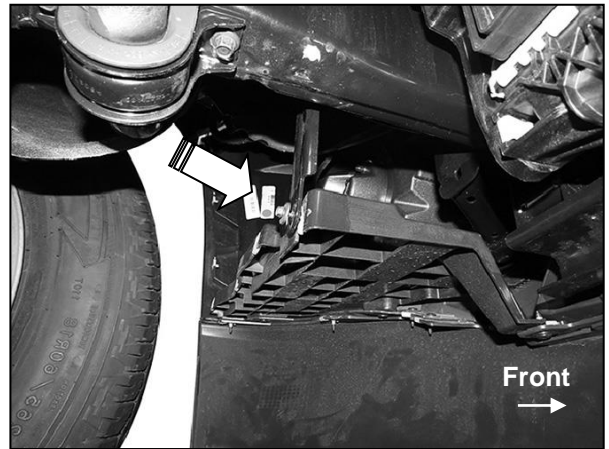

(Fig 4) Remove hardware attaching plastic fill panels to inner fender, (arrow). Driver/left side pictured from behind bumper

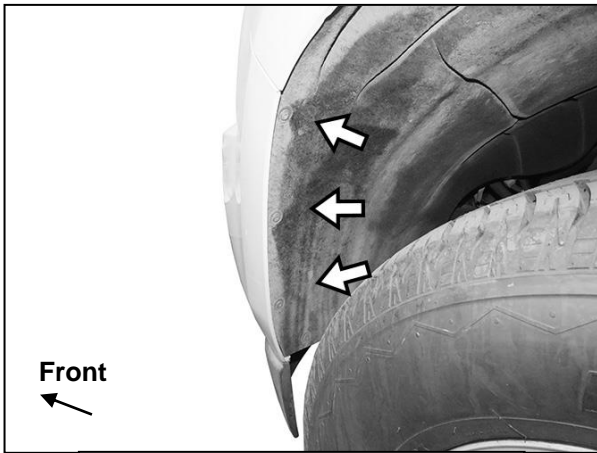

(Fig 5) Remove screws attaching fender liner to bumper cover

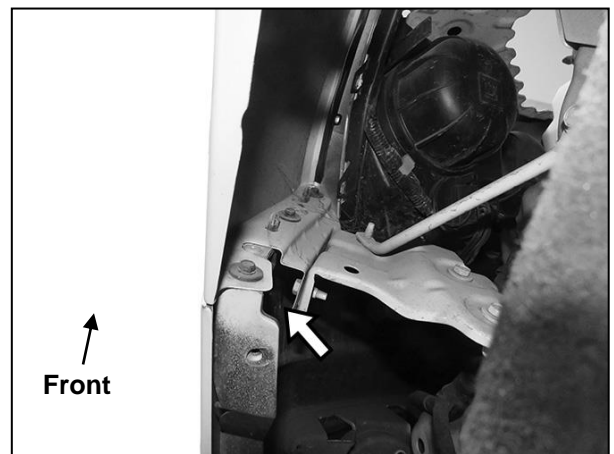

(Fig 6) Remove hardware attaching bumper cover to fender

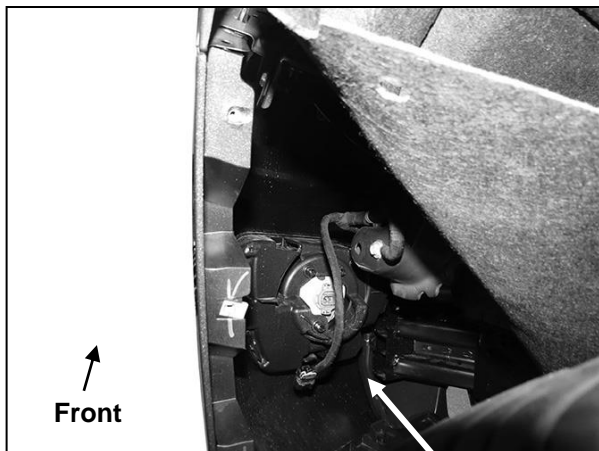

(Fig 7) Pull back fender liner to access bumper hardware and unplug fog light if

**CS1 LD FRONT BUMPER
2015-20 CHEVY COLORADO
(EXCLUDES DIESEL, ZR2 MODELS)**

Driver/left Side Installation Pictured

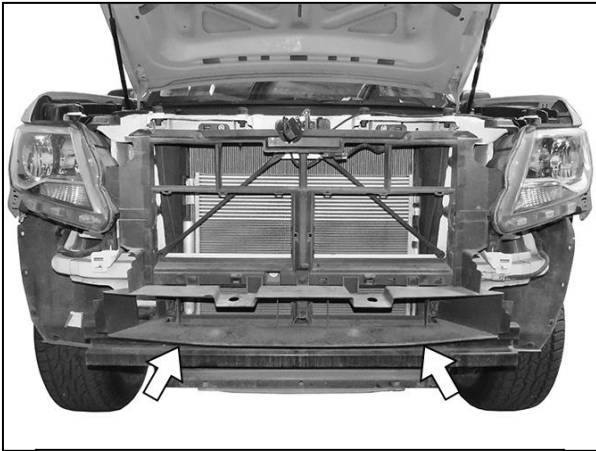

(Fig 8) Remove outer bumper assembly. Remove air deflector (arrows)



(Fig 9) Remove (2) hex bolts (arrows) from driver/left side of impact bumper

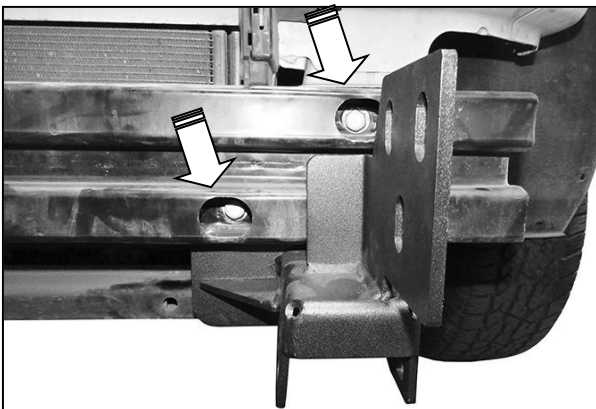

(Fig 10) Insert driver/left Frame Bracket between impact bumper and frame. Reuse factory hex bolts to attach Bracket to frame

- (2) 12mm x 90mm Hex Bolts
- (4) 12mm x 24mm STD Flat Washers
- (2) 12mm Nylon Lock Nuts

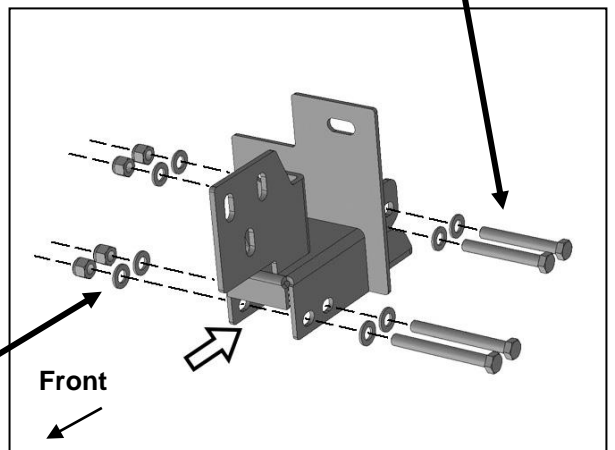

- (2) 12mm x 110mm Hex Bolts
- (4) 12mm x 24mm STD Flat Washers
- (2) 12mm Nylon Lock Nuts

(Fig 11) Attach bottom mount on Frame Bracket to frame. Attach tow hook, if equipped, to front of Frame Bracket (arrow)

**CS1 LD FRONT BUMPER
2015-20 CHEVY COLORADO
(EXCLUDES DIESEL, ZR2 MODELS)**

Driver/left Side Installation Pictured

- (2) 12mm x 90mm Hex Bolts
- (4) 12mm x 24mm STD Flat Washers
- (2) 12mm Nylon Lock Nuts

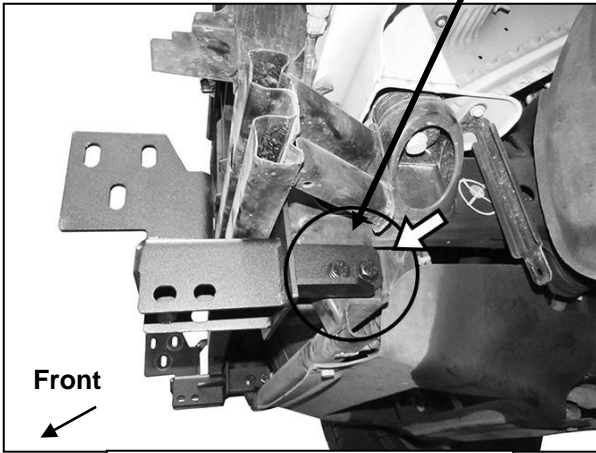

(Fig 12) Attach bottom mount on Frame Bracket to frame

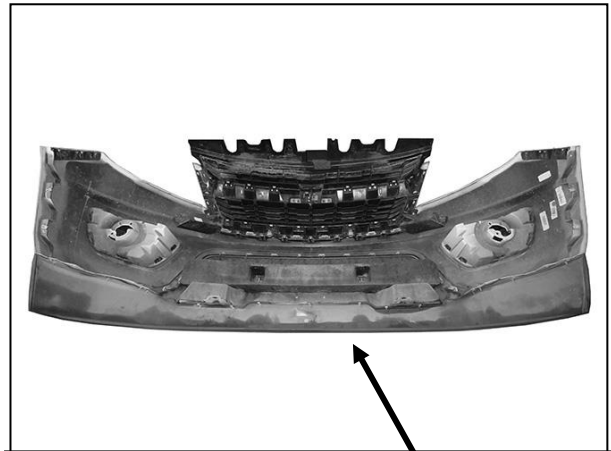

(Fig 13) Remove air dam from factory bumper

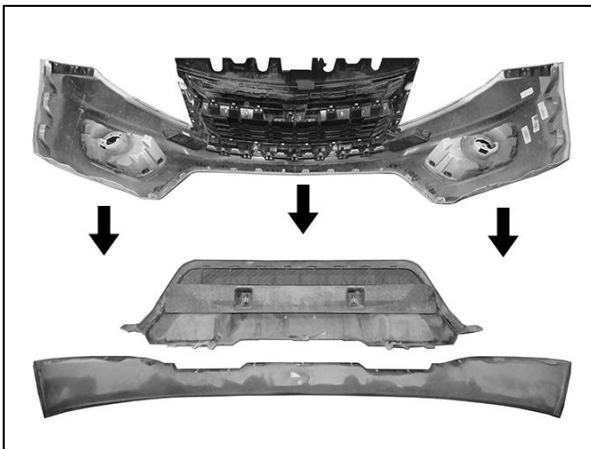

(Fig 14) Remove air dam and lower grille from factory bumper

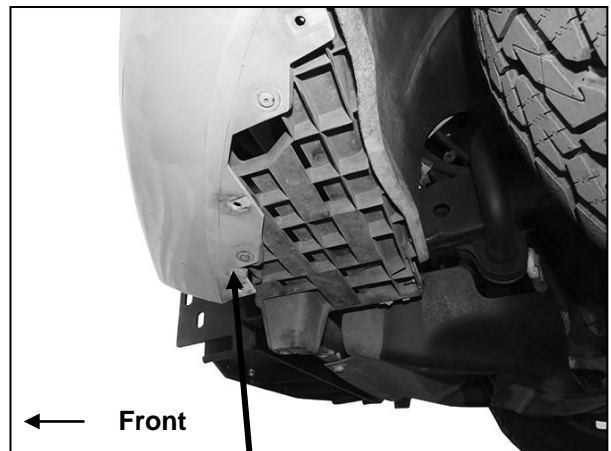

(Fig 15) Reinstall bumper and grill assembly. Reattach outer bumper cover to plastic bumper reinforcements

**CS1 LD FRONT BUMPER
2015-20 CHEVY COLORADO
(EXCLUDES DIESEL, ZR2 MODELS)**

Driver/left Side Installation Pictured

- (2) 8mm x 25mm Hex Bolts
- (4) 8mm Flat Washers
- (2) 8mm Lock Washers
- (2) 8mm Hex Nuts

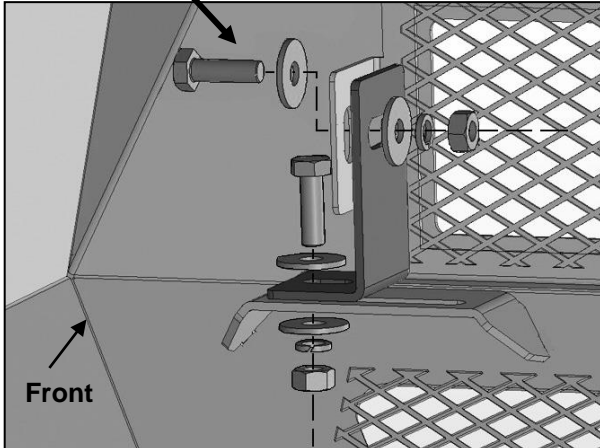

**(Fig 16) Attach Center Fill Panel to "L" Brackets
(Do not install Fill Panel with LED light)**

- 8mm x 25mm Hex Bolt
- (2) 8mm Flat Washers
- 8mm Lock Washer
- 8mm Hex Nut

- 8mm x 16mm Hex Bolt
- 8mm Lock Washer
- 8mm Flat Washer

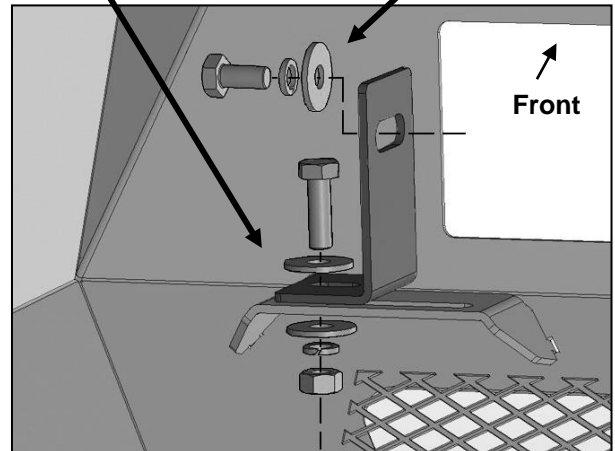

(Fig 17) Attach "L" Brackets if installing LED center light (not included) or Center Fill Panel

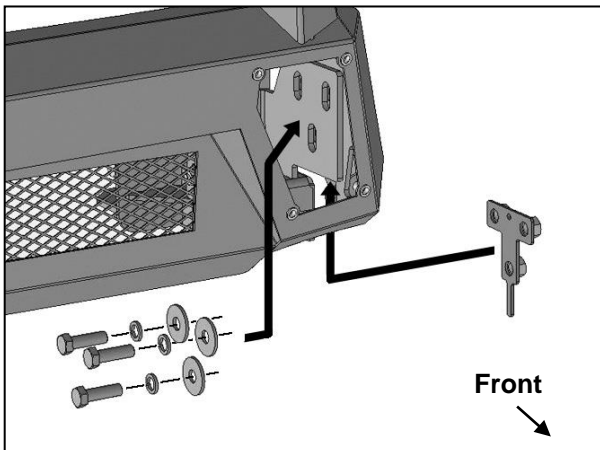

(Fig 18) Insert Triple Nut Plate through outer end of CS1 Bumper. Insert hardware through opening in Bumper and out through Bracket and Bumper and into Nut Plate

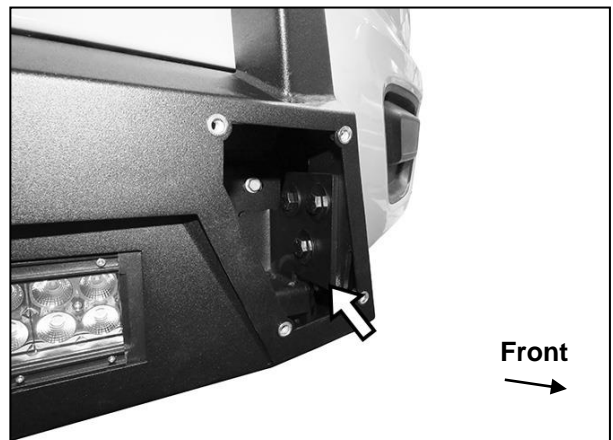

(Fig 19) Insert hardware through opening in Bumper and out through Bracket, Bumper and into Nut Plate

**CS1 LD FRONT BUMPER
2015-20 CHEVY COLORADO
(EXCLUDES DIESEL, ZR2 MODELS)**

Driver/left Side Installation Pictured

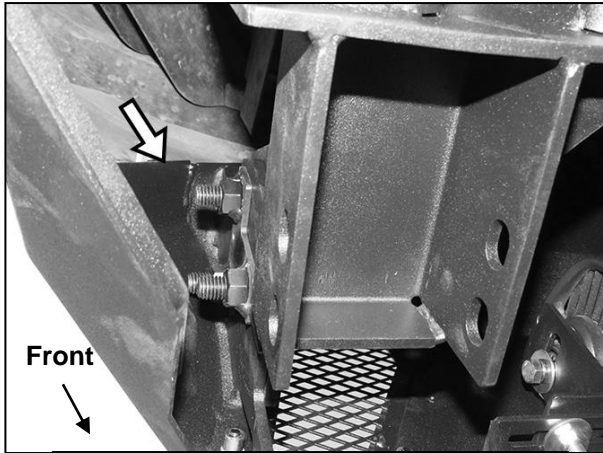

(Fig 20) Driver/left side of CS1 Bumper installation illustrated from below

- 8mm x 25mm Hex Bolt
- (2) 8mm Flat Washers
- 8mm Lock Washer
- 8mm Hex Nut

- 8mm x 16mm Hex Bolt
- 8mm Lock Washer
- 8mm Flat Washer

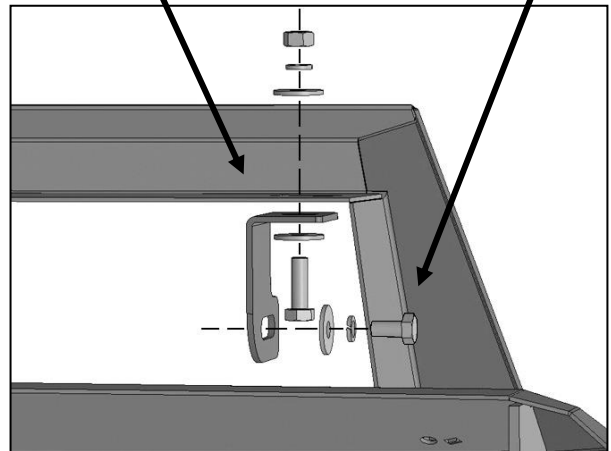

(Fig 21) Attach LED Bar Light "L" Brackets to bull nose (light not included, installation is optional)

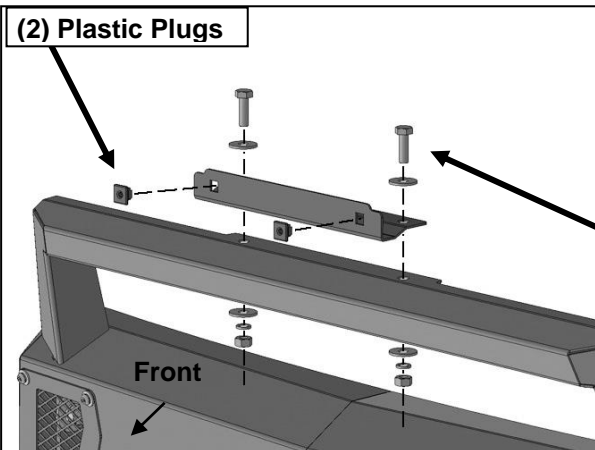

- (2) Plastic Plugs

- (2) 8mm x 25mm Hex Bolts
- (4) 8mm Flat Washers
- (2) 8mm Lock Washers
- (2) 8mm Hex Nuts

- (4) 6mm Combo Bolts

(Fig 22) Attach Mesh Fill Panels (optional). Push in Plastic Plugs for license plate if required

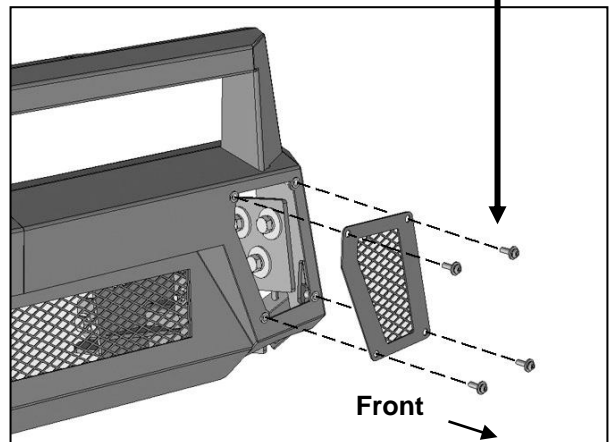

(Fig 23) Attach Mesh Fill Panels (optional). Push in Plastic Plugs for license plate if required



**Complete installation
(light not included)**