



## **INSTALLATION INSTRUCTIONS**

**BEACON BULL BAR FOR Honda Ridgeline 06-15 \*\*Pilot 03-08\*\* Acura  
MDX 01-06  
PART # BE-HORIB**

**PARTS LIST:**

1	3" Bull Bar
1	Driver/left Side Mounting Bracket
1	Passenger/right Side Mounting Bracket
4	12-1.75mm x 30mm Hex Bolts
8	12mm x 24mm x 2.5mm Flat Washers
4	12mm Lock Washers
4	12-1.75mm Hex Nuts

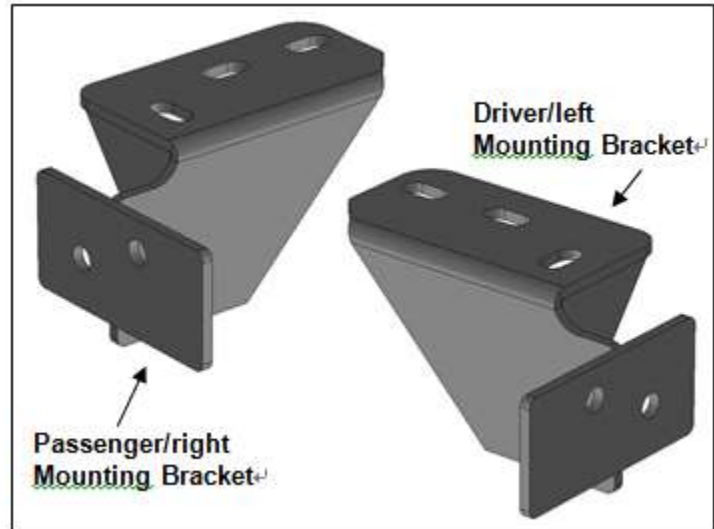

**PROCEDURE:**

**REMOVE CONTENTS FROM BOX. VERIFY ALL PARTS ARE PRESENT. READ INSTRUCTIONS CAREFULLY. ASSISTANCE IS RECOMMENDED. CUTTING IS REQUIRED.**

1. Remove the plastic splash guard under the front bumper. **NOTE:** There may be several two-piece plastic push-in clips holding the splash guard up to the vehicle. Pry the center pin up with a small flat blade screwdriver to release and remove the entire clip. Once all clips have been removed, place the splash guard on a clean and stable work surface.
2. Starting at the driver/left front of the vehicle, locate and remove the two factory bolts securing the driver/left frame support to the bottom of the front crossmember, **(Figures 1 & 2)**. Next, remove the hex bolt from the crossmember next to the support bracket.
3. Gently pull down on the support bracket just enough to slide the driver/left Mounting Bracket between the support bracket and the crossmember, **(Figure 2)**. **NOTE:** Do not pull too hard or you may bend the support bracket. If more room is required to insert the Mounting Bracket between the support bracket and crossmember, loosen but **DO NOT REMOVE** the large hex bolt securing the inner end of the support bracket to the subframe mount, **(Figure 2)**.
4. Align the holes in the Mounting Bracket with the (2) holes in the support bracket and single threaded hole in the crossmember. Insert the factory hex bolts through the support bracket, the Bull Bar Mounting Bracket and back into the crossmember. Do not fully tighten at this time.
5. Repeat **Steps 2—4** for the passenger/right side Mounting Bracket installation, **(Figure 3)**.
6. With assistance, attach the Bull Bar to the outside of the Mounting Brackets with the included (4) 12mm Hex Bolts, (8) 12mm Flat Washers, (4) 12mm Lock Washers and (4) 12mm Hex Nuts, **(Figure 4)**. Level and adjust the Bull Bar position as necessary then fully tighten only the Mounting Bracket to crossmember hardware and large subframe bolts if previously loosened, **(Step 3, Figures 2 & 3)**.
7. Hold the splash guard up in position against the bottom of the Brackets. Mark the location of the Brackets onto the inside surface of the splash guard. Make several small cuts to clear the Mounting Brackets, **(Figure 5)**. Reinstall the splash guard using the factory hardware.
8. Repeat **Step 6** to reinstall the Bull Bar.
9. Level and adjust the Bull Bar and tighten all hardware.
10. Do periodic inspections to the installation to make sure that all hardware is secure and tight.

**To protect your investment**, wax this product after installing. Regular waxing is recommended to add a protective layer over the finish. Do not use any type of polish or wax that may contain abrasives that could damage the finish.

**For stainless steel:** Aluminum polish may be used to polish small scratches and scuffs on the finish. Mild soap may be used also to clean the Bull Bar.

**For gloss black finishes:** Mild soap may be used to clean the Bull Bar.

DRIVER SIDE INSTALLATION PICTURED

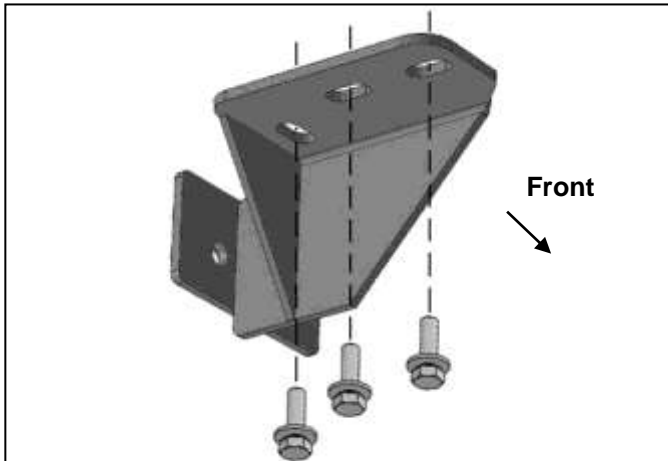

(Fig 1) Reuse factory hex bolts to attach Mounting Brackets, driver/left side illustrated

Loosen but DO NOT REMOVE the large factory hex bolt securing the frame bracket to the subframe mount

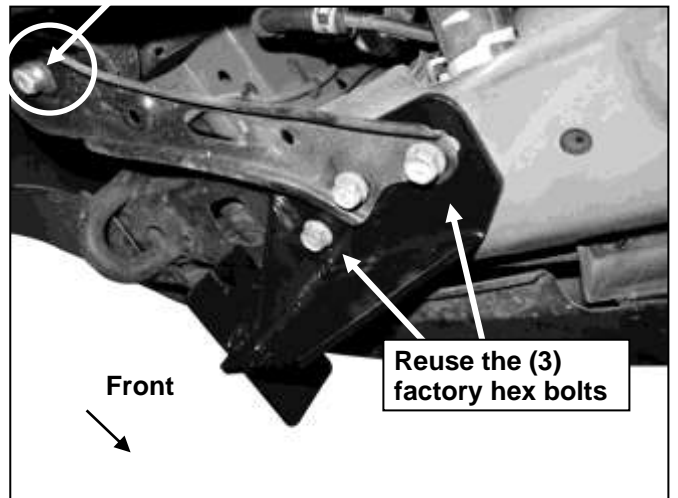

Reuse the (3) factory hex bolts

(Fig 2) Driver/left side Mounting Bracket installed



(Fig 3) Passenger/right Mounting Bracket installed

- (2) 12mm Hex Bolts
- (4) 12mm Flat Washers
- (2) 12mm Lock Washers
- (2) 12mm Hex Nuts

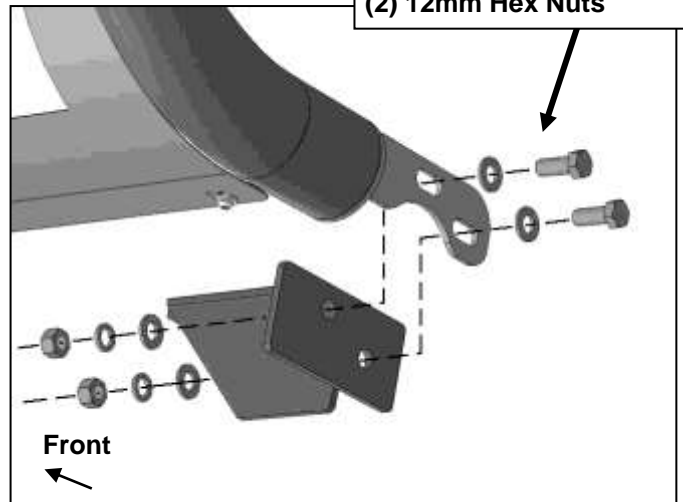

(Fig 4) Attach driver/left side of Bull Bar to outside of Mounting Bracket

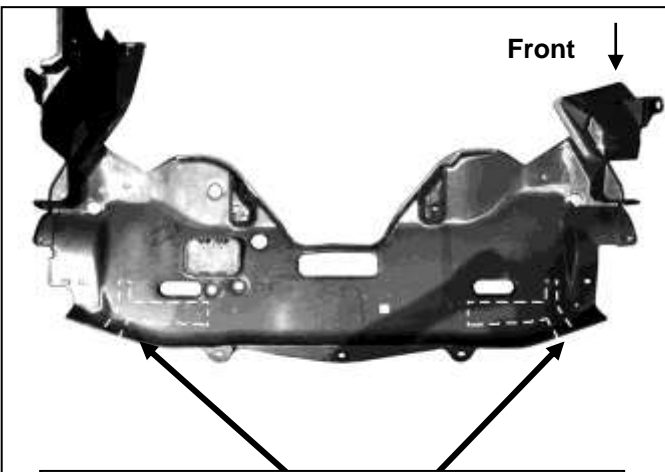

(Fig 5) Approximate cut out area marked on plastic splash guard, use for example only