



TEL: 1-866-XANATOS

INSTALLATION INSTRUCTIONS

**PART # MAB-FOB2601B / MAB-FOB2601S
BULL BAR FOR FORD ESCAPE 08-12/MAZDA TRIBUTE 08-11**

PARTS LIST:

1	Bull Bar	2	12-1.75mm x 50mm Hex Bolts
1	Driver/Left Frame Bracket	4	12-1.75mm x 30mm Hex Bolts
1	Passenger/Right Frame Bracket	10	12mm x 32mm OD x 3mm Flat Washers
1	Driver/Left Bull Bar Bracket	2	12mm Lock Washers
1	Passenger/Right Bull Bar Bracket	4	12mm Nylon Lock Nuts
2	Top Support Brackets	4	10mm x 30mm OD x 2.5mm Flat Washers
1	10-1.50mm Driver Side U-Bolt	4	10mm Nylon Lock Nuts
1	10-1.50mm Passenger Side U-Bolt	2	8mm x 24mm OD x 2mm Flat Washers
2	8-1.25mm x 20mm Bolt Plate (58mm x 18mm plate)	2	8mm Nylon Lock Nuts
2	8mm Plastic Retainers		

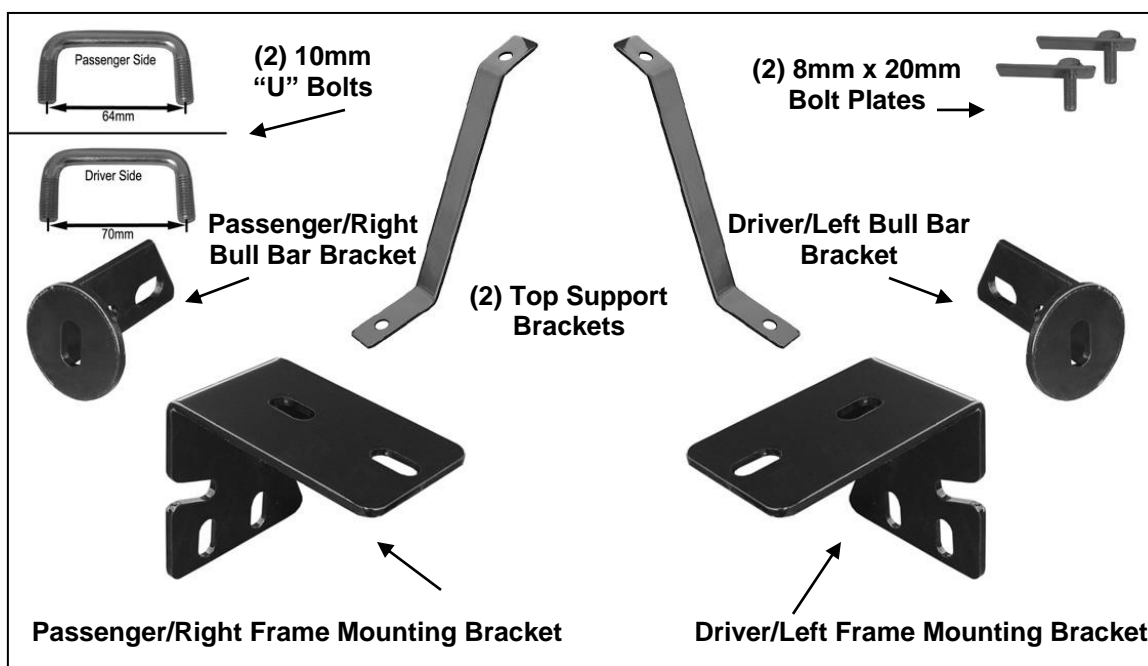
**PROCEDURE:**

- REMOVE CONTENTS FROM BOX. VERIFY ALL PARTS ARE PRESENT. READ INSTRUCTIONS CAREFULLY BEFORE STARTING INSTALLATION. CUTTING IS REQUIRED. ASSISTANCE IS RECOMMENDED.**
- From under the front of the vehicle, remove the passenger and driver side plastic splash guards and the lower air dam.
- Starting on the driver side, locate the two non-threaded factory holes in the bottom of the cross member. Insert the wider, driver side 10mm "U" Bolt, (**Figure 1B**), into one hole and back out the second hole as pictured in **Figure 1A**.
- Temporarily hold the driver side plastic splash guard up in position to determine correct area to cut to clear Bracket. Place driver side Bracket over U-Bolt. Trim the plastic splash guards as pictured in **Figures 2A & 2B**.
- Re-Install the splash guard with the factory hardware. **NOTE:** One mounting tab will be cut from each splash guard. The Mounting Bracket will now help hold the splash guard in place, (**Figure 3**).
- Position the driver side Frame Mounting Bracket over the "U"-Bolt and splash guard. Secure the Bracket to the "U"-Bolt with (2) 10mm Nylon Lock Nuts and (2) 10mm Flat Washers (**Figure 4**). Do not

tighten hardware at this time. **NOTE:** Once the Mounting Bracket is fully tightened, it will help hold the splash guard in place. Trim and fit the splash guard as needed for a proper fit.

7. Repeat **Steps 3 - 6** for passenger side Frame Mounting Bracket installation.
8. Hold the air dam up in position to determine area to be cut to clear both Brackets, (**Figure 4**). Measure and mark 12-1/2" from the outside and towards the inside of each end of the plastic lower air dam, (**Figures 5A & 5B**). **NOTE:** Do not follow the contour of the air dam when measuring. Use a hacksaw to cut out a 1" gap on each marked location on the air dam. **NOTE:** The air dam will now be in (3) pieces. Re-install the air dam using the factory bolt and the clips.
9. Next, move up to the lower grille opening. At the top of the opening, locate the outer plastic clip. Use a flat blade screwdriver to release and remove the plastic clip, (**Figure 6**). Insert (1) 8mm Bolt Plate into and down through the factory hole, (**Figures 7A and 7B**). To help hold the Bolt Plate in place, 8mm Plastic Retainers have been provided. Thread the Plastic Retainer down the Bolt Plate until it is flat against the sheetmetal.
10. Select (1) Top Bracket. Bolt the short end of the Top Bracket to the Bolt Plate with (1) 8mm Nylon Lock Nut and (1) 8mm Flat Washer, (**Figures 8A & 8B**). Leave hardware loose at this time.
11. Repeat **Steps 9 & 10** for passenger side Top Support Bracket installation.
12. Carefully unwrap the Bull Bar and place it on a clean stable work surface. Remove the top two outer screws securing the skid plate to the crossbar on the Bull Bar, (**Figure 9**). **NOTE:** This will be the Top Bracket mounting location.
13. Select the driver side Bull Bar Mounting Bracket. Bolt the Bracket to the end of the tube on the Bull Bar using (1) 12mm x 50mm Hex Bolt, (1) 12mm Lock Washer and (1) 12mm Flat Washer, (**Figure 10**). Snug but do not tighten hardware at this time. Repeat this Step for passenger side Bull Bar Bracket installation.
14. With assistance, position the Bull Bar onto the outside of the (2) Frame Mounting Brackets. Attach the Bull Bar to the Brackets with (4) 12mm x 30mm Hex Bolts, (8) 12mm Flat Washers and (4) 12mm Nylon Lock Nuts, (**Figure 11**). Do not tighten hardware at this time.
15. Attach the (2) Top Brackets to the cross bar on the Bull Bar using the (2) screws removed in **Step 12**, (**Figure 12**).
16. Level and adjust the Bull Bar and tighten all hardware.
17. Do periodic inspections to the installation to make sure that all hardware is secure and tight.

To protect your investment, wax this product after installing. Regular waxing is recommended to add a protective layer over the finish. Do not use any type of polish or wax that may contain abrasives that could damage the finish.

For stainless steel: Aluminum polish may be used to polish small scratches and scuffs on the finish. Mild soap may be used also to clean the Bull Bar.

For gloss black finishes: Mild soap may be used to clean the Bull Bar.

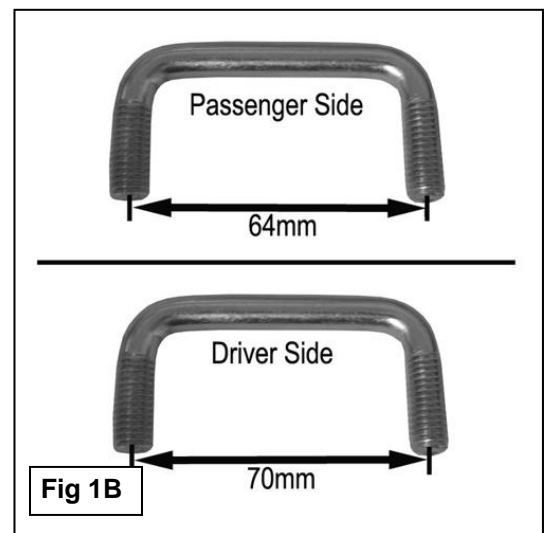
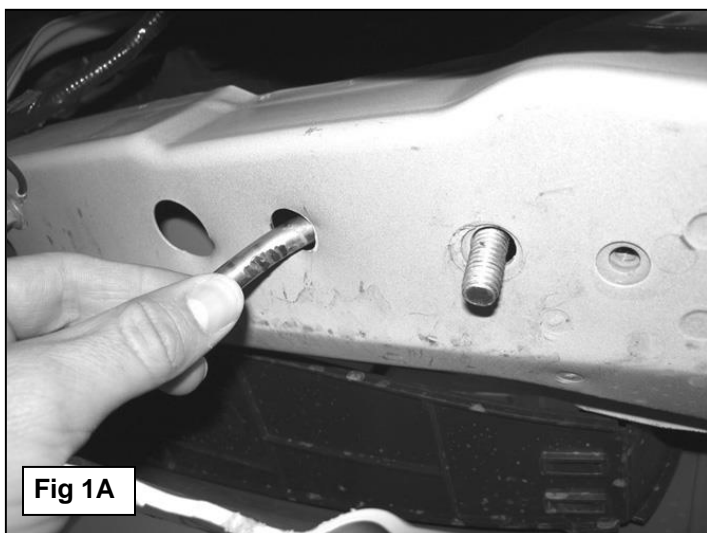

ALL MEASUREMENTS FOR REFERENCE ONLY-CHECK BEFORE CUTTING

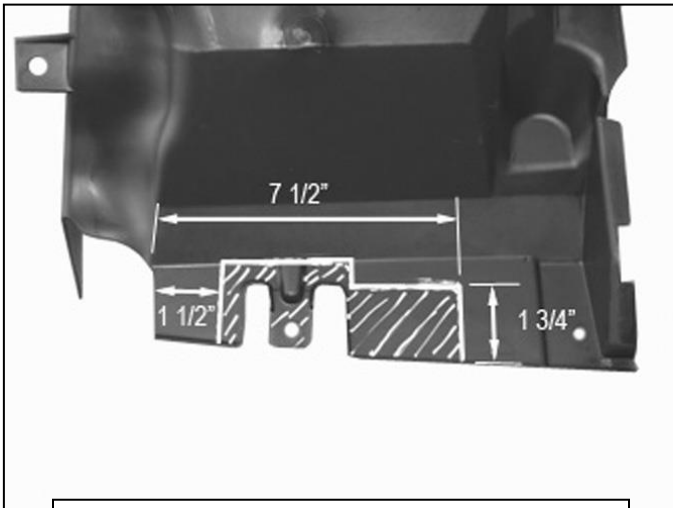

(Fig 2A) Driver Side Splash Guard Pictured

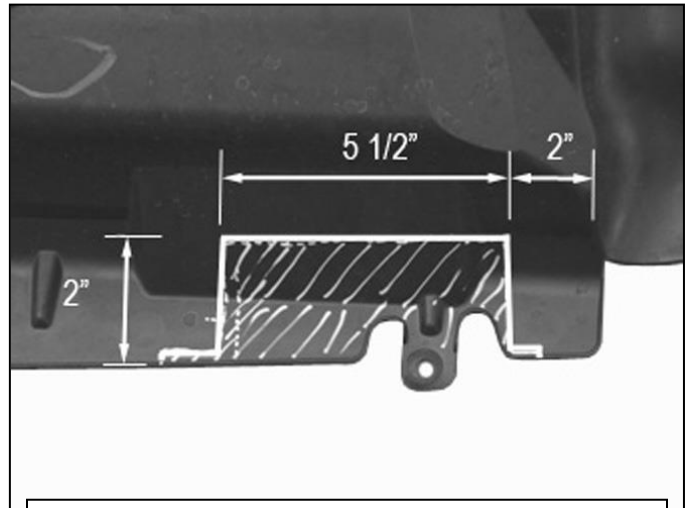

(Fig 2B) Passenger Side Splash Guard Pictured

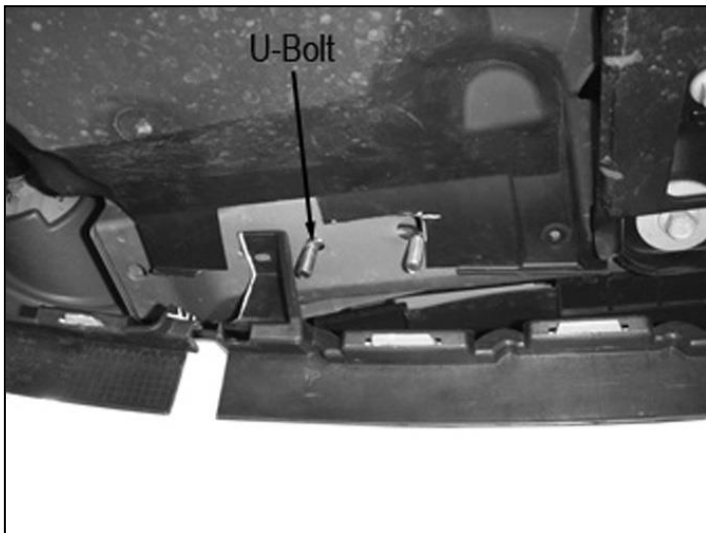

(Fig 3) Driver Side Splash Guard Pictured

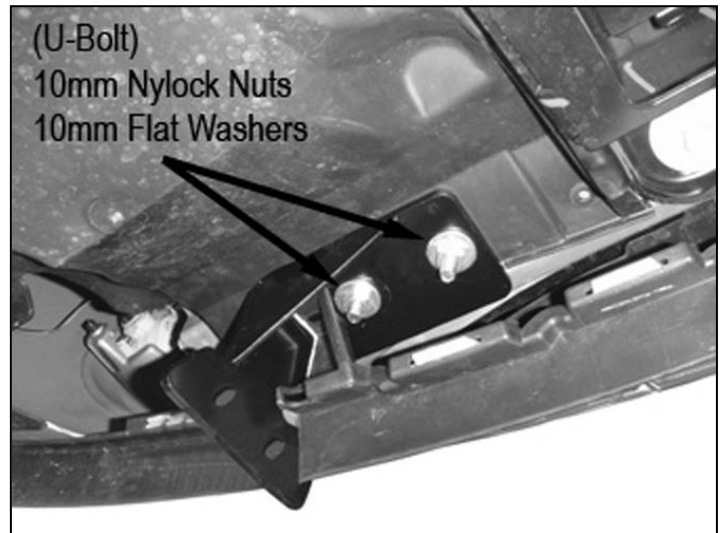

(Fig 4) Driver Side Splash Guard Pictured

ALL MEASUREMENTS FOR REFERENCE ONLY-CHECK BEFORE CUTTING

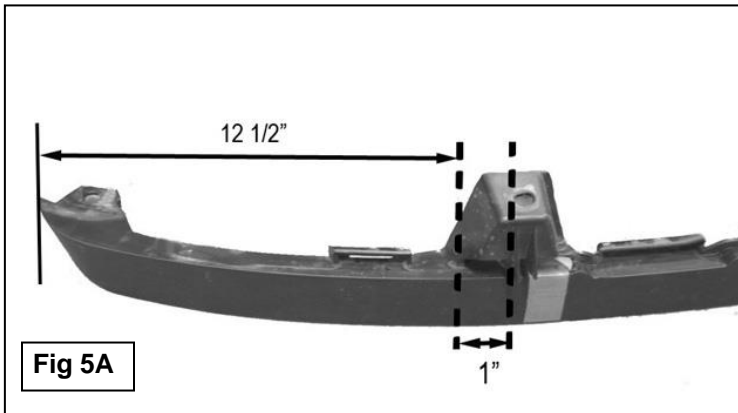

Fig 5A

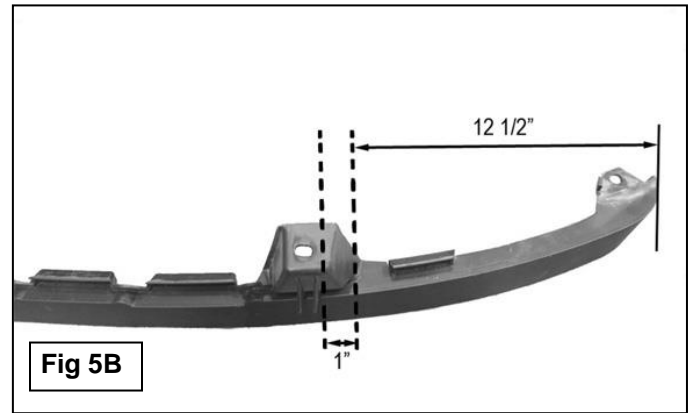
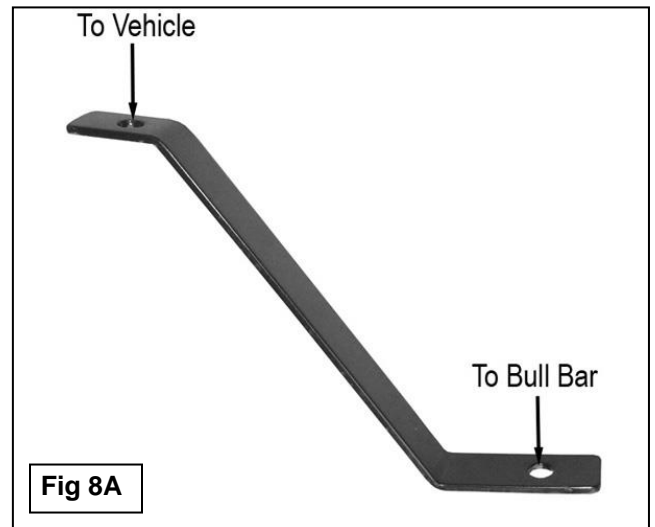
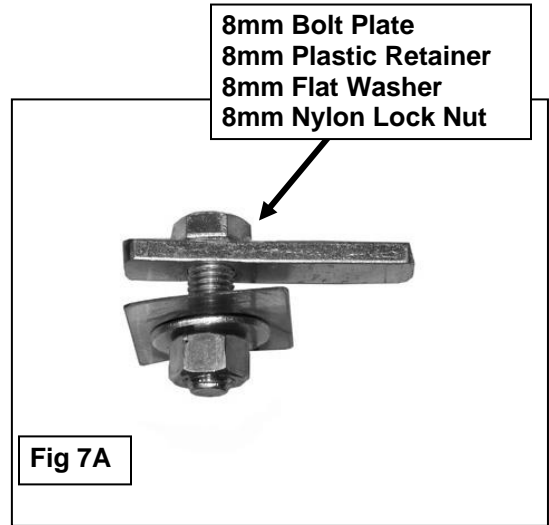
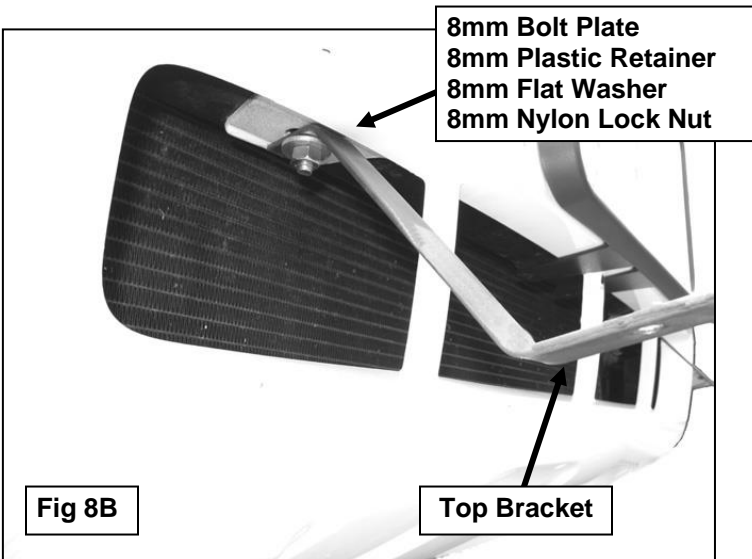
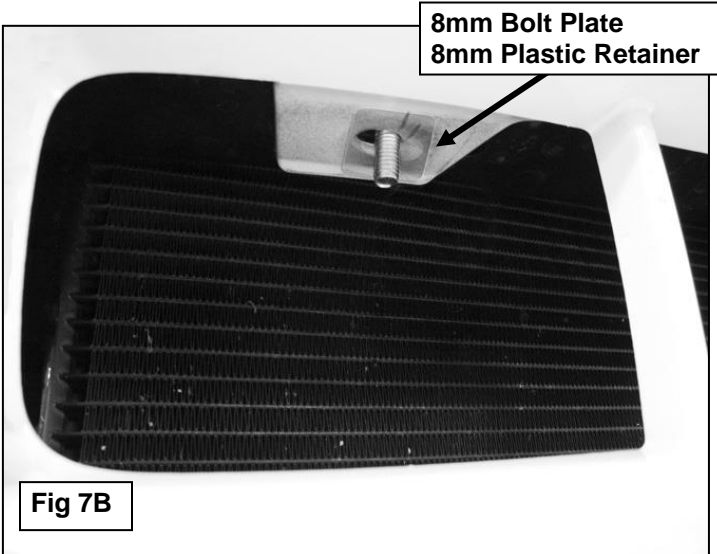
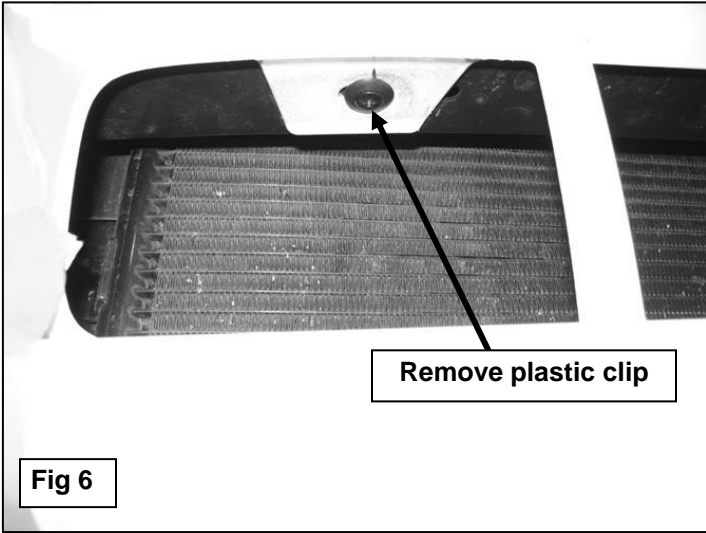

Fig 5B

Passenger Side Installation Pictured



Passenger Side Installation Pictured

Remove (2) outer screws in bottom of crossbar

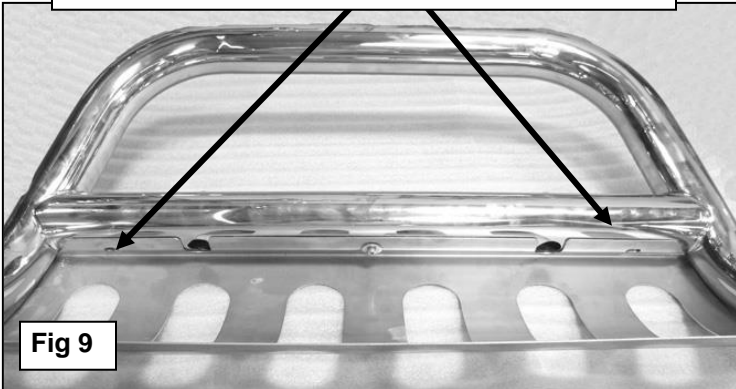

(2) 12mm x 50mm Hex Bolts
(2) 12mm Flat Washers
(2) 12mm Lock Washers

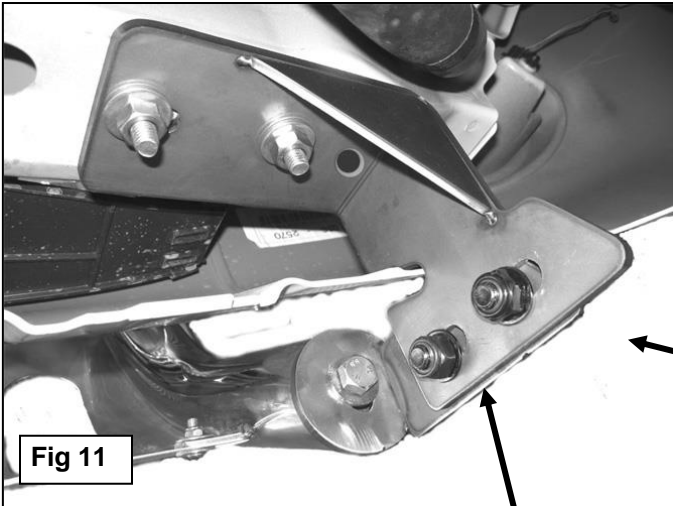
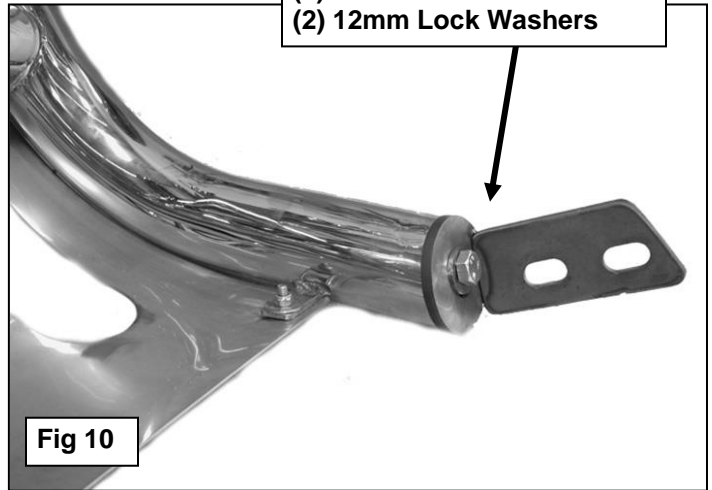

Passenger side Mounting Bracket
pictured installed without splash guard
or air dam for instruction purposes

(2) 12mm x 30mm Hex Bolts
(4) 12mm Flat Washers
(2) 12mm Nylon Lock Nuts

