



TEL: 1-866-XANATOS

INSTALLATION INSTRUCTIONS

MAX BULL BAR

2011-2022 Jeep Grand Cherokee

2011-2013 Dodge Durango

Excl. Limited X, High Altitude, Summit, SRT, SRT8, Trackhawk and
Trailhawk

MBS-JEB9206

PARTS LIST:

1	Bull Bar
1	Driver/Left Side Frame Mounting Bracket
1	Passenger/Right Side Frame Mounting Bracket
8	10-1.5mm x 35mm Hex Bolts
12	10mm x 30mm OD x 2.5mm Flat Washers
8	10mm Lock Washers
4	10mm Hex Nuts



Complete Installation

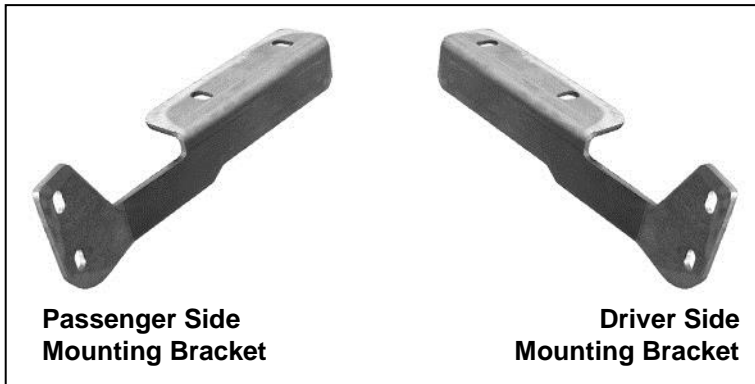

PROCEDURE:

- 1. REMOVE CONTENTS FROM BOX. VERIFY ALL PARTS ARE PRESENT. READ INSTRUCTIONS CAREFULLY BEFORE STARTING INSTALLATION. ASSISTANCE IS RECOMMENDED.**

IMPORTANT: This Bull Bar is not compatible with optional Adaptive Cruise Control-Forward Collision Warning Systems featuring grille mounted laser control sensor.

- 2011-13 vehicles without factory tow hooks:** Determine if the vehicle is equipped with or without factory tow hooks, **(Figure 1)**. If vehicle is equipped with tow hooks, remove both tow hooks and skip ahead to **Step 4**. **NOTE:** Tow hooks cannot be reinstalled with the Bull Bar.
 - 2011-13 vehicles without factory tow hooks:** Remove the plastic splash guard, **(Figure 2)**. Pay close attention to the type and location of all factory hardware for easier reinstallation. Release the clips at the ends of the plastic bumper cover that attach the lower cover to the upper cover, **(Figure 3)**. **NOTE:** It is not necessary to remove the lower cover, only release the clips at the ends of the cover. Next, remove the (3) clips fastening the air deflector to the bottom of the crossmember, **(Figure 4)**. Pull the bumper cover forward for access and pull the air deflector out from behind the bumper cover, **(Figure 5)**. Release the clips securing the (2) block off covers to the ends of the air deflector, **(Figure 6)**. Remove the (2) block offs. Reinstall the air deflector using the factory hardware. Reinstall the bumper cover.
 - 2014 vehicles without tow hooks, (Figure 7):** Remove the hardware attaching the bottom of the driver side front fender liner to the back of the bumper and splash guard, **(Figure 8)**. Pull back the liner and reach up from behind the bumper to locate the plastic cover on each end of the lower grille, **(Figure 9)**. Push to release the plastic clips on the outer edge of the cover to remove the cover from the grille opening, **(Figure 10)**. Repeat this **Step** for passenger side. **NOTE:** It is not required but installation may be slightly easier with the center splash guard removed.
- Select the driver side Frame Mounting Bracket. Line up the (2) slots in the bracket with the (2) threaded holes in the bottom of the frame channel, **(Figure 11)**. Bolt the Bracket to the frame

channel with (2) 10mm x 35mm Hex Bolts, (2) 10mm Flat Washers and (2) 10mm Lock Washers, **(Figure 12)**. Do not tighten hardware at this time. Repeat this Step for passenger side Frame Bracket installation.

4. With assistance, hold the Bull Bar up to the outside of the Mounting Brackets. Attach the Bull Bar to the Mounting Brackets with the included (4) 10mm x 35mm Hex Bolts, (8) 10mm Flat Washers, (4) 10mm Lock Washers and (4) 10mm Hex Nuts, **(Figure 13)**.
5. Align and adjust the Bull Bar and tighten all hardware. Reinstall the splash guard and/or fender liners if removed, **(see Step 2)**.
6. Do periodic inspections to the installation to make sure that all hardware is secure and tight.

To protect your investment, wax this product after installing. Regular waxing is recommended to add a protective layer over the finish. Do not use any type of polish or wax that may contain abrasives that could damage the finish.

For stainless steel: Aluminum polish may be used to polish small scratches and scuffs on the finish. Mild soap may be used also to clean the Bull Bar.

For gloss black finishes: Mild soap may be used to clean the Bull Bar.

Driver Side Installation Pictured



2011-13 Tow hook mounting location pictured through opening in front bumper cover. Remove tow hook if equipped

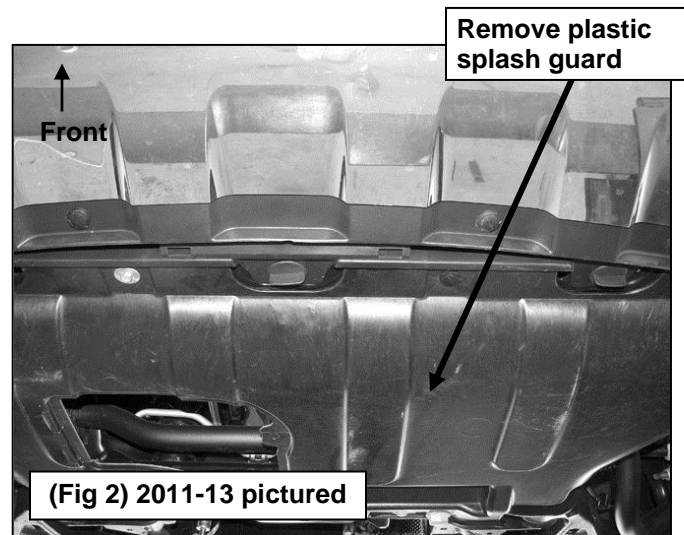

Remove plastic splash guard



(Fig 3) 2011-13: Separate lower bumper cover from upper bumper cover at ends only

Driver Side Installation Pictured

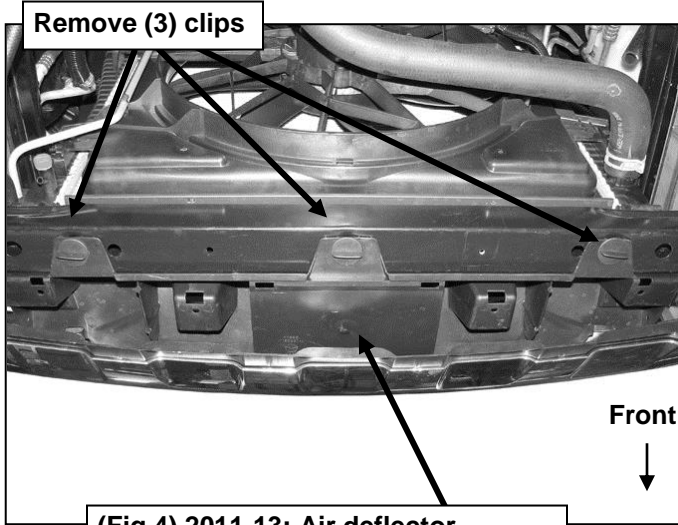

(Fig 4) 2011-13: Air deflector pictured from below front bumper

2011-13: Carefully pull bumper cover forward to remove air deflector

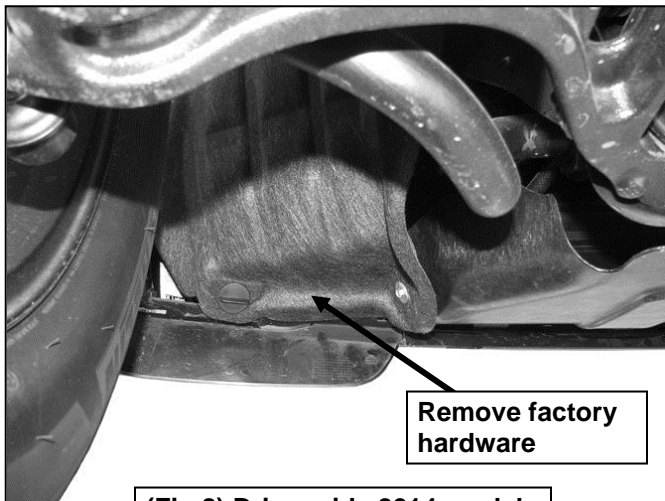
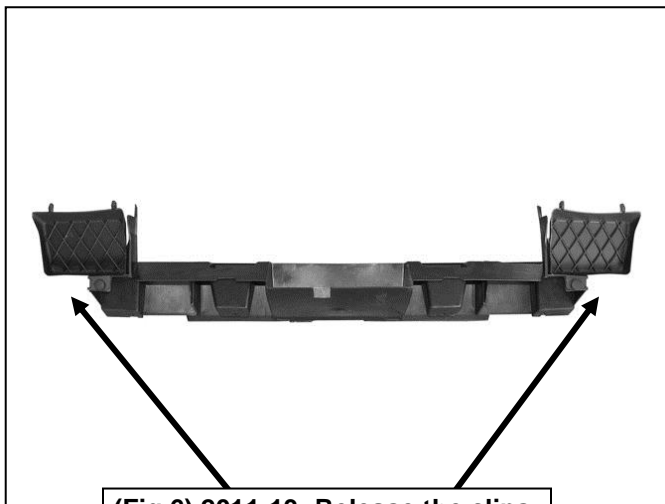
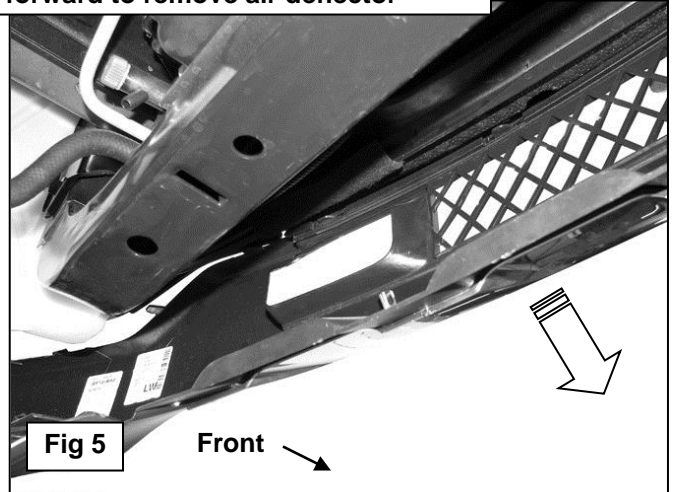

Driver Side Installation Pictured

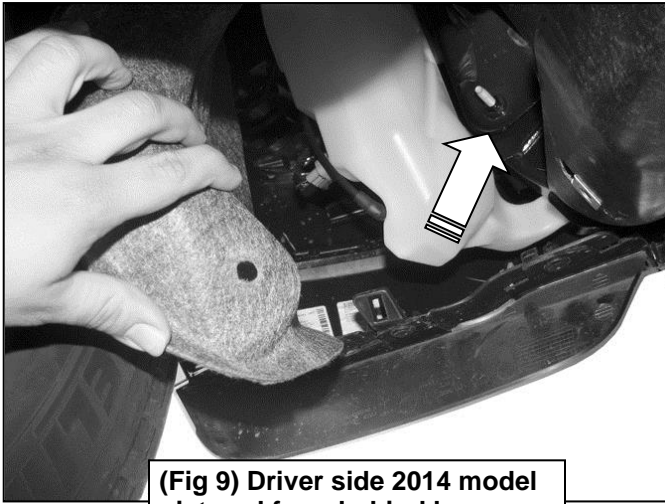

(Fig 9) Driver side 2014 model pictured from behind bumper



(Fig 10) Driver side 2014 model pictured

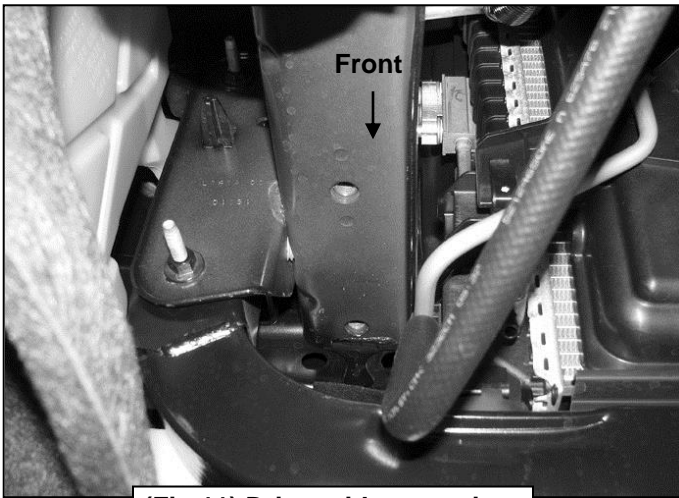

(Fig 11) Driver side mounting location pictured from below

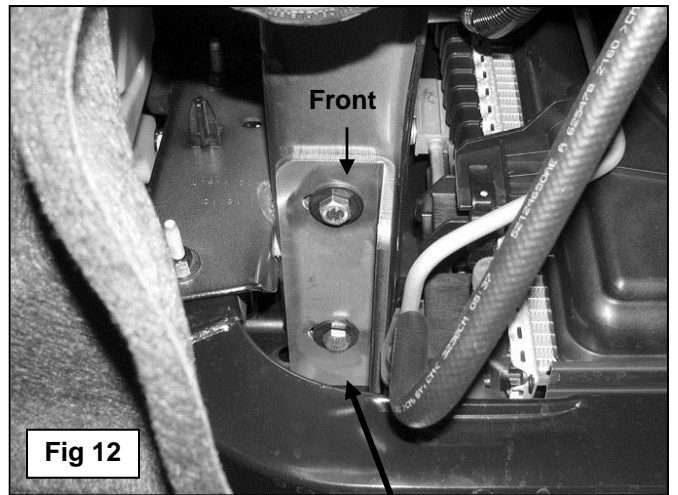

Fig 12

- (2) 10mm x 35mm Hex Bolts
- (2) 10mm Flat Washers
- (2) 10mm Lock Washers

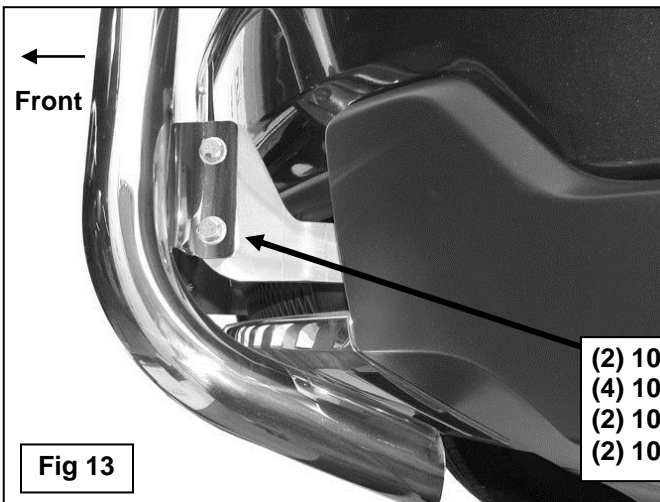

Fig 13

- (2) 10mm x 35mm Hex Bolts
- (4) 10mm Flat Washers
- (2) 10mm Lock Washers
- (2) 10mm Hex Nuts