



**BLACK HORSE
OFF ROAD®**

TEL: 1-866-XANATOS

INSTALLATION INSTRUCTIONS

ARMOUR BULL BAR

19-24 DODGE RAM 1500

(Excl. Rebel & TRX Trim, 19-24 Ram 1500 Classic and 20-22 Ram 1500 Diesel Models)

PART#DO11/AB-DO11-NL

(Excl. Rebel & TRX Trim, 19-24 Ram 1500 Classic and 20-22 Ram 1500 Diesel Models)

PARTS LIST:

1	Bull Bar	4	10mm x 30mm OD x 2.5mm Flat Washers
1	Driver/Left Side Frame Mounting Bracket	2	8mm Bolt Plates
1	Passenger/Right Side Frame Mounting Bracket	2	8mm Plastic Retainers
1	Driver/Left Side Bull Bar Bracket	12	8mm Lock Washers
1	Passenger/Right Side Bull Bar Bracket	18	8mm x 24mm OD x 2mm Flat Washers
1	Driver/Left Side Support Bracket	6	8mm Hex Nuts
1	Passenger/Right Side Support Bracket	2	8mm Nylon Lock Nuts
1	Driver/Left Side Light Bar Bracket	6	8mm x 30mm Hex Bolts
1	Passenger/Right Side Light Bar Bracket	2	8mm x 20mm Hex Bolts
1	Mesh	2	8mm x 16mm Hex Bolts
1	License Plate Bracket	4	6mm x 18mm OD x 1.6mm Flat Washers
2	Rubber Sensor Plugs	2	6mm x 20mm Button Head Screws
4	12mm x 35mm Hex Bolts	2	6mm Lock Washers
8	12mm x 32mm OD x 3mm Flat Washers	2	6mm Hex Nuts
4	12mm Lock Washers	2	6mm x 20mm Combo Bolts
4	12mm Hex Nuts	4	4mm x 10mm Button Head Allen Screws
4	10mm x 25mm Hex Bolts	1	Wrench S=4
4	10mm Lock Washers	1	Wrench S=2.5

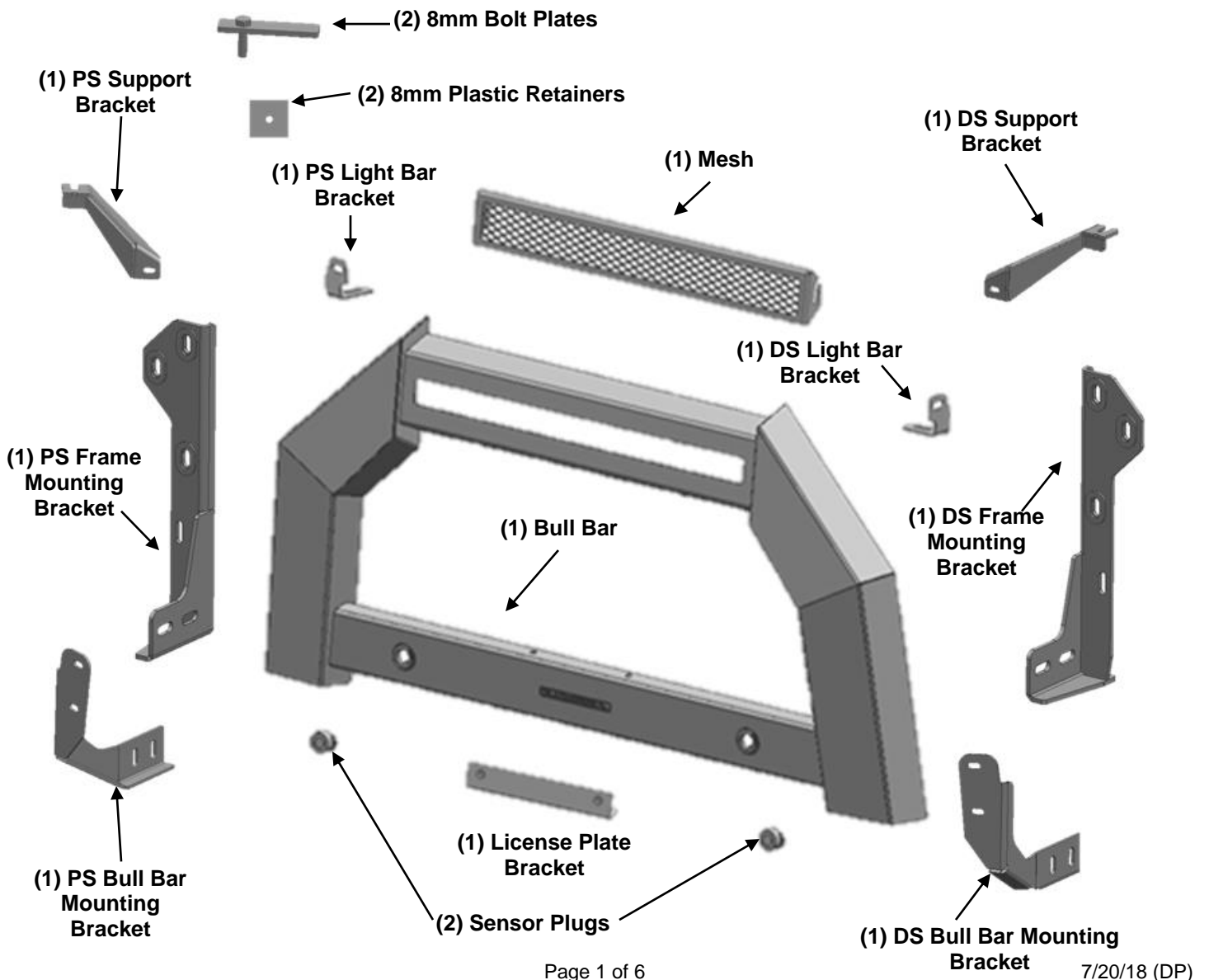

PROCEDURE:

REMOVE CONTENTS FROM BOX. VERIFY ALL PARTS ARE PRESENT. READ INSTRUCTIONS CAREFULLY BEFORE STARTING INSTALLATION. CUTTING IS REQUIRED. ASSISTANCE IS RECOMMENDED. INSTALLATION MAY INTERFERE WITH FRONT BUMPER MOUNTED SENSORS.

1. Start installation under the front bumper. Carefully remove the plastic lower air dam attached to the bottom of the bumper. Do not remove the electronic “active air dam” behind the bumper if equipped. Pay close attention to the type and location of all factory hardware for reinstallation.
2. Move to the back of the driver/left side of the bumper, **(Figure 1)**. Select (1) 8mm Bolt Plate and (1) 8mm Plastic Retainer. Insert the Bolt Plate into the space between the outer bumper cover and bumper bracket, **(Figure 2)**. Insert the threaded part of the Bolt Plate back through the hole in the bumper bracket. Thread the Plastic Retainer onto the Bolt Plate to hold it in place position. **NOTE:** The Plastic retainer is used to help hold the Bolt Plate in place but use is not mandatory for Bracket installation.
3. Next, Remove the (2) factory hex bolts attaching the bumper to the bumper bracket, **(Figure 2)**. Select the driver/left Frame Mounting Bracket. Attach the Bracket to the back of the bumper with the included longer (2) 8mm x 35mm Hex Bolts, (2) 8mm Lock Washers and (2) 8mm Flat Washers, **(Figure 3)**. Attach the Bracket to the 8mm Bolt Plate with (1) 8mm Flat Washer, (1) 8mm Lock Washer and (1) 8mm Hex Nut. Do not fully tighten hardware at this time.
4. Loosen but do not remove the hex bolt from the bottom of the frame, **(Figures 1 & 5)**. Select the driver/left Support Bracket, **(Figure 4)**. Insert the slotted end of the Bracket under the hex bolt.
 - a. On models with tow hooks, slide the Bracket between the head of the hex bolt and the large flat washer, **(Figure 5)**. Do not tighten hex bolt at this time.
 - b. On models without tow hooks, slide the Bracket between the steel sleeve on the frame and the head of the hex bolt, **(Figures 1 & 4)**.
5. Line up the lower end of the Support Bracket with the slot in the Frame Bracket. Attach the Support Bracket to the Frame Bracket with (1) 8mm x 30mm Hex Bolt, (2) 8mm Flat Washers, (1) 8mm Lock Washer and (1) 8mm Hex Nut, **(Figure 4)**.
6. Repeat **Steps 2—5** to install the passenger/right Frame and Support Bracket.
7. Relocation of front license plate is not required, but strongly recommended. Attach the License Plate Bracket to the Bull Bar with (2) 6mm Button Head Bolts, (4) 6mm Flat Washers, (2) 6mm Lock Washers and (2) 6mm Hex Nuts, **(Figure 6)**. Use (2) 6mm Combination Bolts to attach the front license plate to the Bracket, **(Figure 6)**.
8. **Mesh and LED Light installation, (LED light sold separately)**. Select the driver/left side Light Bar Bracket. Attach the Bracket to the back of the mounting plate on the Bull Bar with (1) 8mm x 20mm Hex Bolt, (2) 8mm Flat Washers, (1) 8mm Lock Washer and (1) 8mm Hex Nut, **(Figure 7)**. Repeat this step to attach the passenger/right side Light Bar Bracket to the back of the Bull Bar. Do not tighten hardware.

LED Light Installation

 - a. Use (2) 8mm x 16mm Hex Bolts, (2) 8mm Lock Washers and (2) 8mm Flat Washers to attach the Light Bar Brackets to the Bull Bar, **(Figure 8)**.
 - b. Follow the light manufacturer’s instructions to attach the Bull Bar.
 - c. Follow light manufacturer’s instructions to properly wire the Bull Bar.

Mesh installation

 - a. Use (2) 8mm x 16mm Hex Bolts, (4) 8mm Flat Washers, (2) 8mm Lock Washers and (2) 8mm Hex Nuts to attach the Mesh to the inside surface of the Light Bar Brackets, **(Figure 9)**.
 - b. Level and adjust the Brackets to the Mesh Panel and fully tighten hardware.
9. Select the (2) Sensor Plugs. Push the sensor plugs into the sensor sleeves behind the Bull Bar **(Figure 10)**.
10. With assistance, hold up the assembled Bull Bar to the Bull Bar Brackets. Align the (2) bottom holes on the Uprights with the Brackets. Bolt the assembled Bull Bar to the Brackets with (4) 10mm x 25mm Hex Bolts, (4) 10mm Lock Washers and (4) 10mm x 30mm Flat Washers, **(Figures 11)**.
11. Level and adjust the Bull Bar properly and tighten all hardware.
12. Do periodic inspections to the installation to make sure that all hardware is secure and tight.

(Excl. Rebel & TRX Trim, 19-24 Ram 1500 Classic and 20-22 Ram 1500 Diesel Models)

To protect your investment, wax this product after installing. Regular waxing is recommended to add a protective layer over the finish. Do not use any type of polish or wax that may contain abrasives that could damage the finish. Mild soap may be used to clean the Bull Bar.

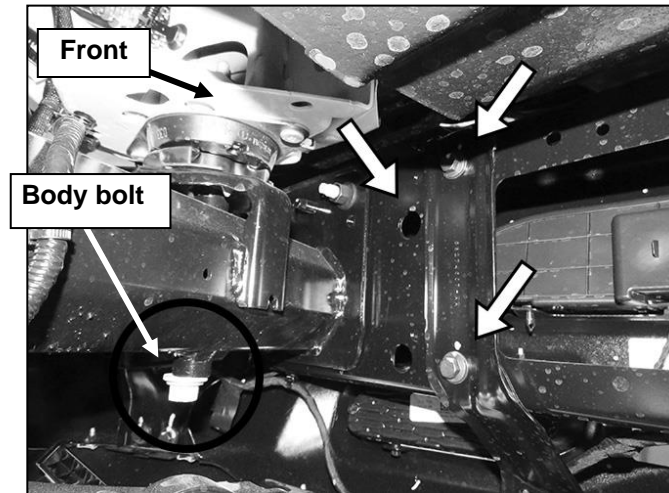

**(Fig 1) Driver/left mounting location
pictured from behind bumper**

(Excl. Rebel & TRX Trim, 19-24 Ram 1500 Classic and 20-22 Ram 1500 Diesel Models)

Driver Side Installation Pictured

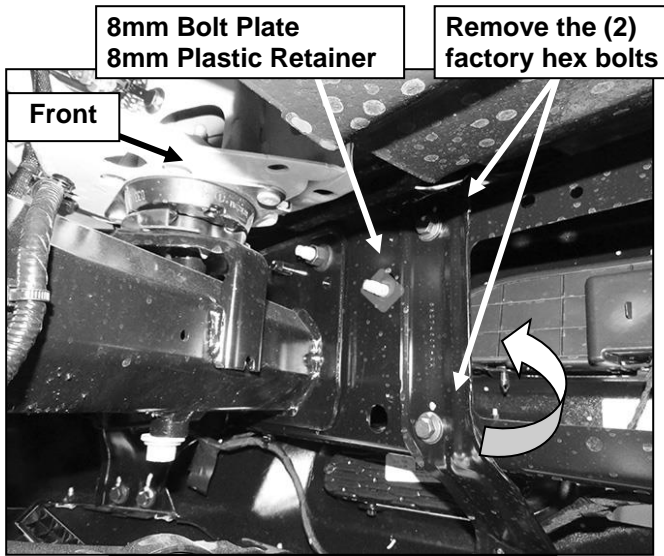

(Fig 2) Insert Bolt Plate back through bumper bracket (arrow)

- (2) 8mm x 35mm Hex Bolts
 - (2) 8mm Lock Washers
 - (2) 8mm Flat Washers
- 8mm Flat Washer
 - 8mm Lock Washer
 - 8mm Hex Nut

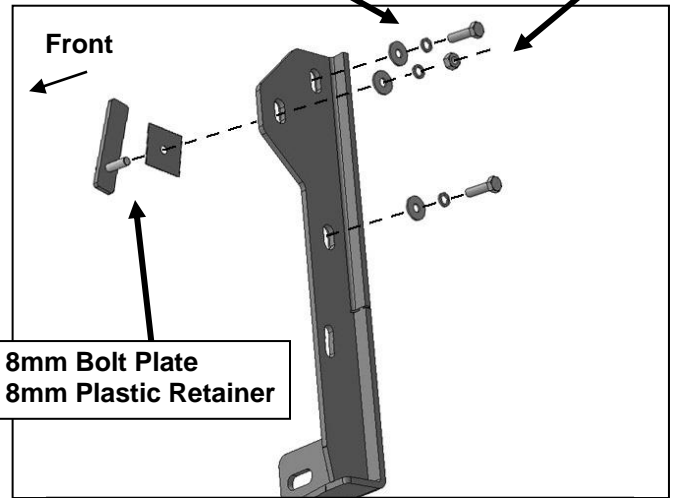

(Fig 3) Driver/left side Frame Bracket layout

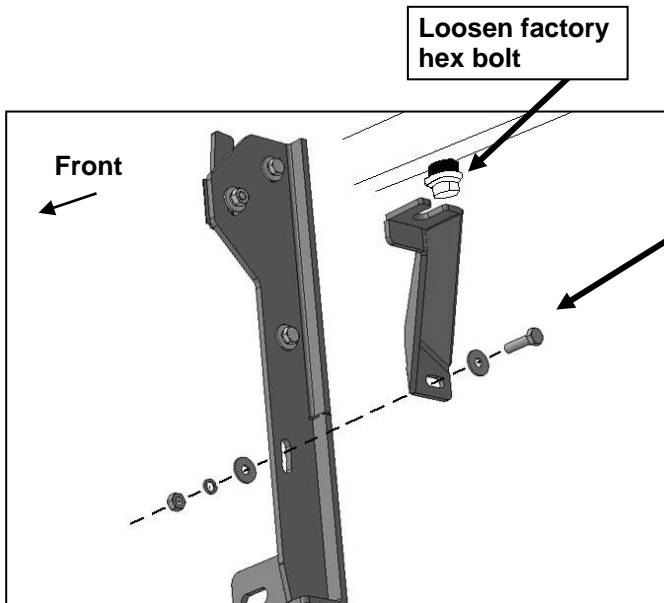

(Fig 4) Driver/left side Support Bracket attached to factory bolt and Frame Bracket

- 8mm x 30mm Hex Bolt
- (2) 8mm Flat Washers
- 8mm Lock Washer
- 8mm Hex Nut

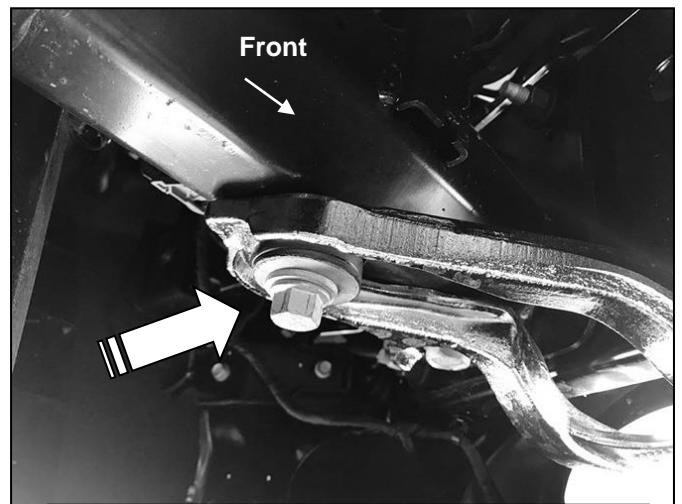

(Fig 5) Models with tow hook, loosen rear bolt (arrow) and slide top of Support Bracket between head of bolt and large flat washer

Driver Side Installation Pictured

(2) 6mm Combo Bolts

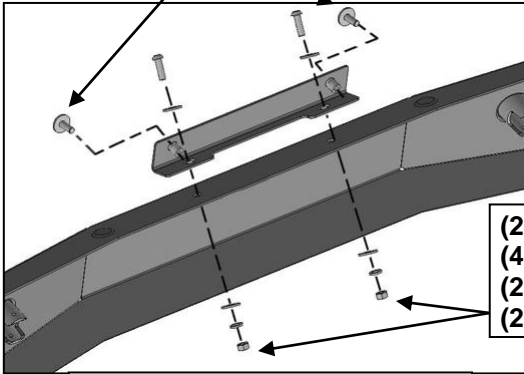

(2) 6mm Button Head Bolts
(4) 6mm Flat Washers
(2) 6mm Lock Washers
(2) 6mm Hex Nuts

(Fig 6) License Plate Bracket attached to the Bull Bar

(1) 8mm x 20mm Hex Bolt
(2) 8mm Flat Washers
(1) 8mm Lock Washer
(1) 8mm Hex Nut

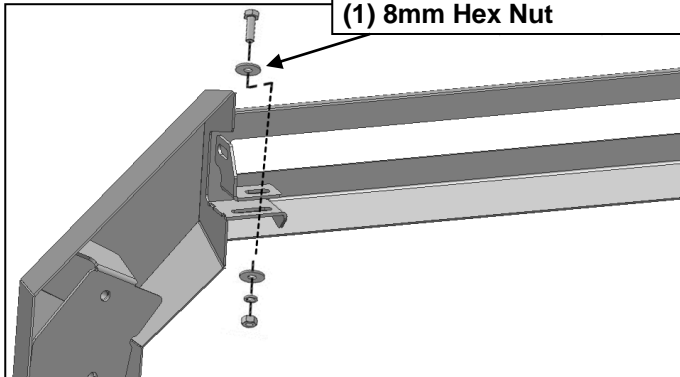

(Fig 7) Driver side light bar Bracket attached to the Bull Bar

8mm x 16mm Hex Bolt
8mm Lock Washer
8mm Flat Washer

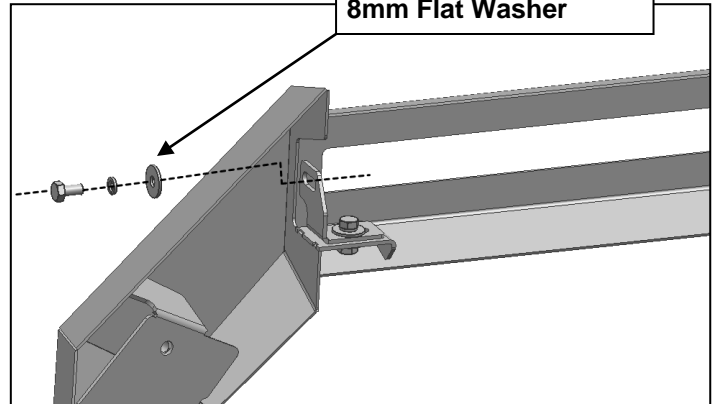

(Fig 8) Driver side light bar Bracket attached to the Bull Bar hardware

(1) 8mm x 16mm Hex Bolt
(2) 8mm Flat Washers
(1) 8mm Lock Washer
(1) 8mm Hex Nut

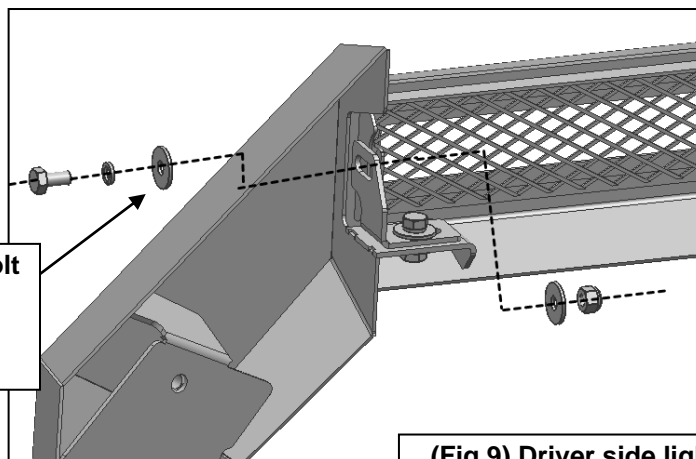

(Fig 9) Driver side light bar Bracket attached to Mesh hardware

(Excl. Rebel & TRX Trim, 19-24 Ram 1500 Classic and 20-22 Ram 1500 Diesel Models)

Driver Side Installation Pictured

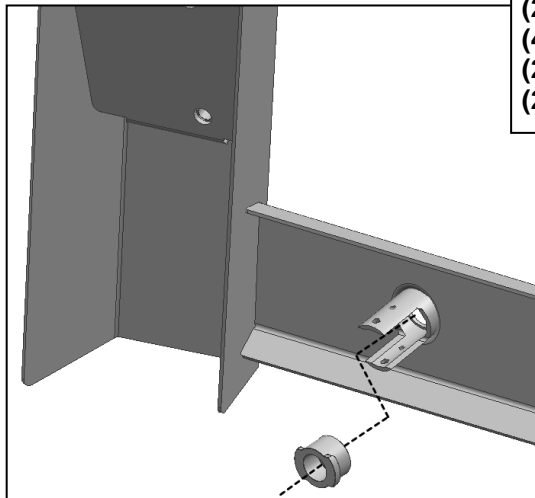

- (2) 12mm Hex Bolt
- (4) 12mm Flat Washers
- (2) 12mm Lock Washer
- (2) 12mm Hex Nut

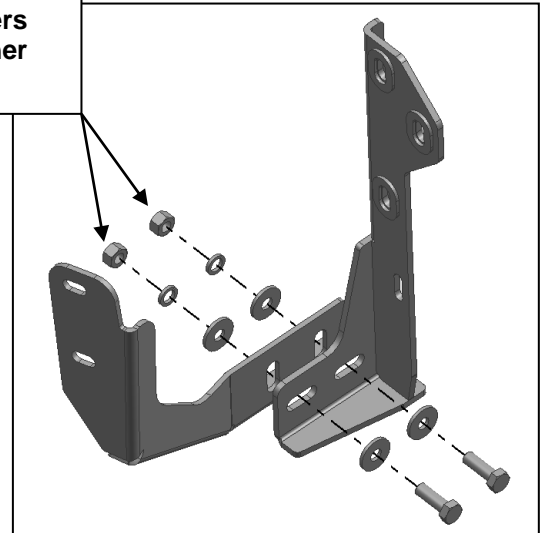

(Fig 10) Attach Sensor Plug into Sensor Sleeve

(Fig 11) Attach the Bull Bar Brackets to the Frame Brackets

- (2) 10mm x 25mm Hex Bolts
- (2) 10mm Lock Washers
- (2) 10mm x 30mm Flat Washers

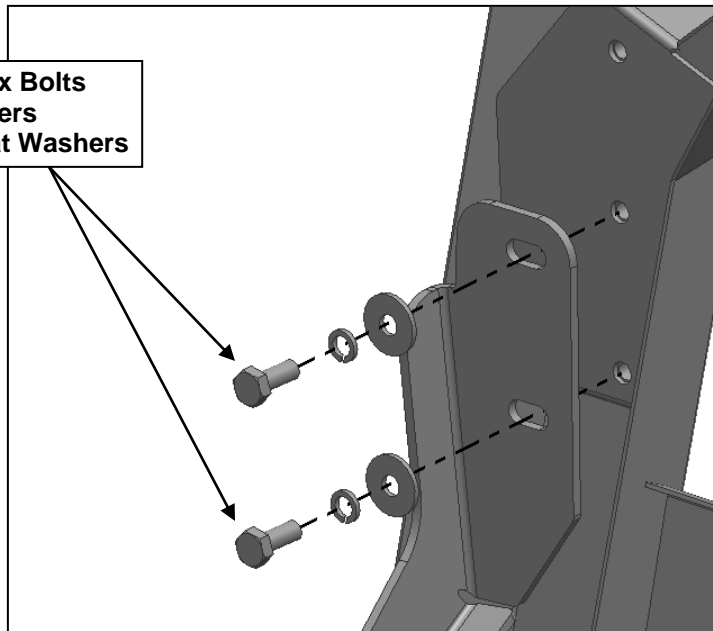

(Fig 12) Attach the Bull Bar to the Bull Bar Brackets