



**BLACK HORSE  
OFF ROAD®**

**TEL: 1-866-XANATOS**

## **INSTALLATION INSTRUCTIONS**

**ARMOUR TIRE CARRIER FOR  
18-24 JEEP WRANGLER JL (Incl. 21-24 4xe)  
PART# ATC-JL18**

**PARTS LIST:**

1	Armour Tire Carrier	8	8mm x 55mm Hex Bolts
1	Upper Light Relocation Bracket	8	8mm Lock Washers
1	Lower Light Relocation Bracket	8	8mm x 24mm OD x 2mm Flat Washers
4	2mm Spacers	8	10mm x 27mm OD x 3mm Flat Washers
4	1.5mm Spacers	2	10mm Nylon Lock Nuts
2	Foam Strips	2	10mm x 30mm Hex Bolts
4	8mm Bolt Plates	4	10mm x 50mm Button Head Allen Bolts
8	8mm Plastic Retainers	4	10mm Lock Washers
1	Allen Wrench S=6	8	6mm x 18mm OD x 1.6mm Flat Washers
1	Allen Wrench S=4	4	6mm Nylon Lock Nuts
8	8mm Nylon Lock Nuts	4	6mm x 20mm Button Head Allen Bolts
8	8mm x 16mm x 1.6mm Flat Washers		

**Upper Light Relocation Bracket**

**Lower Light Relocation Bracket**

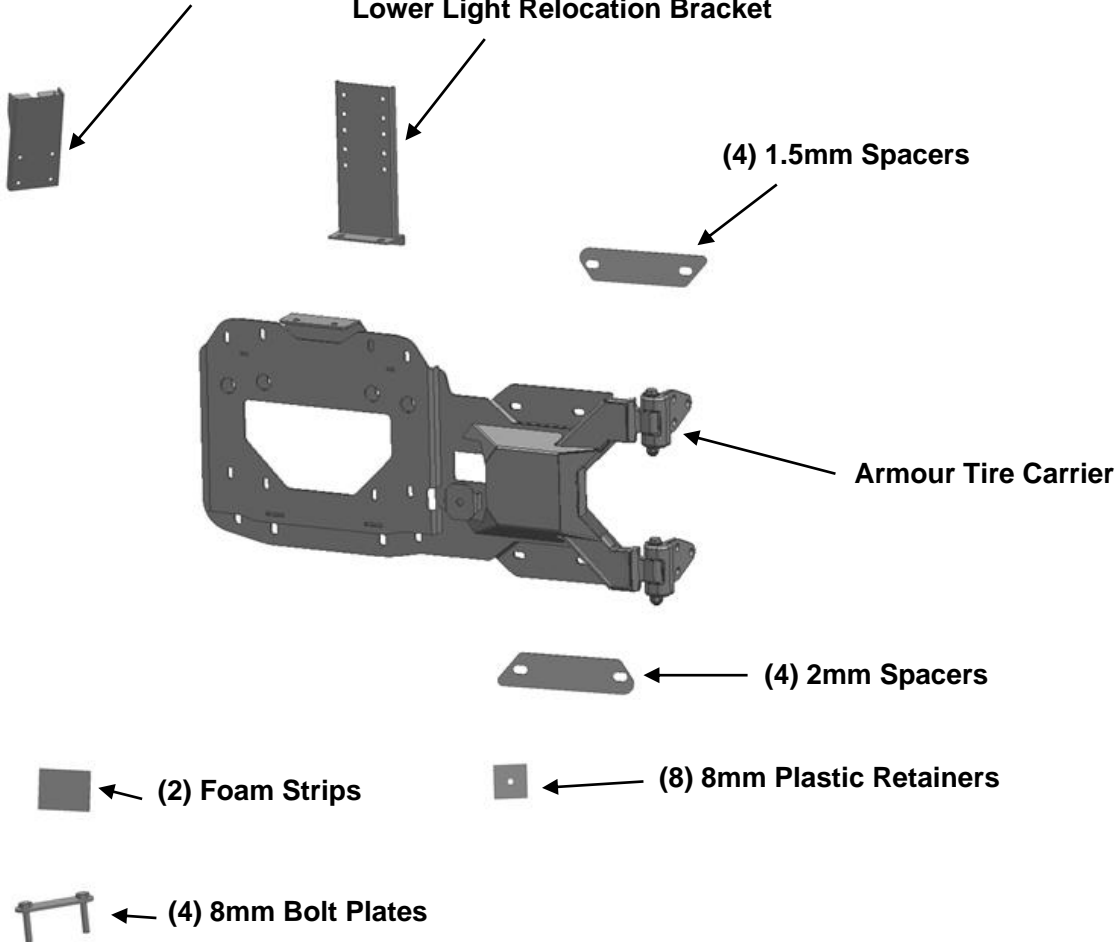

## PROCEDURE

### STEP 1

Start installation at the rear of the vehicle and remove the spare tire.



### STEP 2

Open the tailgate and remove the bolt attaching the door stop check rod to the tailgate. Remove the plastic covers from the tailgate and the right side of the cargo area. Temporarily reattach the check rod to prevent the door from opening too far.

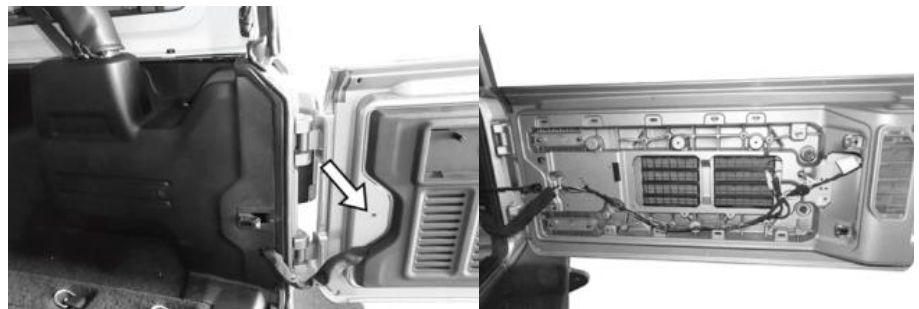

### STEP 3

Locate the camera and CHMSL, (Center High-Mount Stop Light), harness connectors on the back of the tailgate. Unplug the connectors from the back and pull the wires out through the outer hole in the tailgate.



### STEP 4

Remove the (8) factory bolts attaching the OE spare tire carrier and brake light assembly to the tailgate and move it to a clean stable surface.



## PROCEDURE

### STEP 5

Remove the rubber bumper or tire support attached to the tailgate next to the lower hinge.



### STEP 6

Open the tailgate and remove the bolt attaching the door stop check rod to the tailgate. With assistance, remove the (4) factory hinge bolts from the door and move the door to a clean stable work surface.

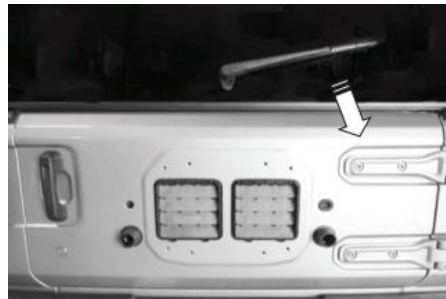

### STEP 7

Remove the (2) factory hinges from the passenger/right side of the cargo area.



### STEP 8

Insert (4) 8mm Bolt Plates through the back of the Relocation Mount, use (8) Plastic Retainers to hold the Bolt Plates.

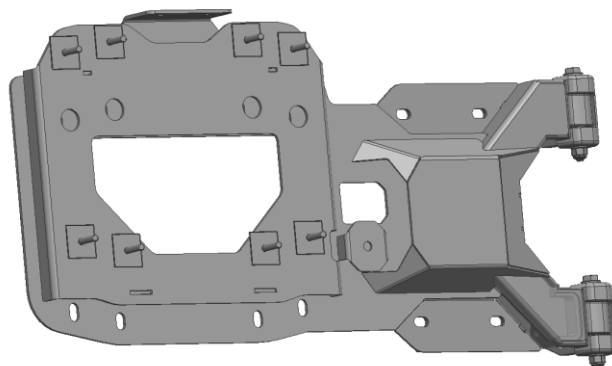

## PROCEDURE

### STEP 9

Carefully place the Relocation Mount assembly on top of the tailgate. Line up the (4) mounting holes on the DS of the Mounting with the holes of the factory spare mount. With the left side of the Mount lined up and flat on the tailgate, check for any gap between the tailgate and the (2) mounting points on the right side of the Mount. Use the included 1.5mm or 2mm Spacers to fill the gap as needed, use if optional.

**NOTE:** Foam Strip has been provided to cover right side of the mount or spacers directly in contact with the painted tailgate. Cut the Foam to fit as needed, use is optional.

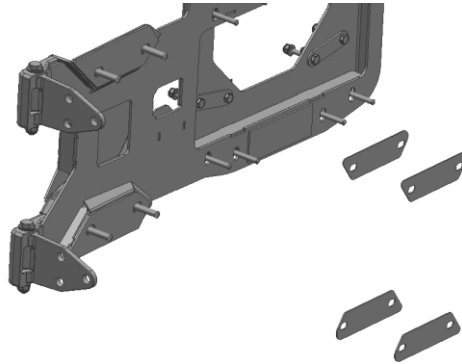

### STEP 10

Attach the right side of the Mount to the door hinge location with:

- (4) 10mm Button Head Bolts
- (4) 10mm Lock Washers
- (4) 10mm Flat Washers

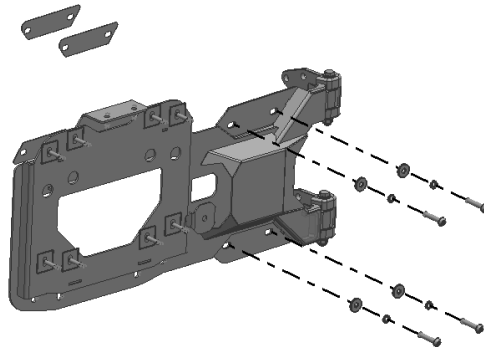

### STEP 11

Attach the left side of the mount to the tailgate with:

- (8) 8mm x 55mm Hex Bolts
- (8) 8mm Lock Washers
- (8) 8mm Flat Washers

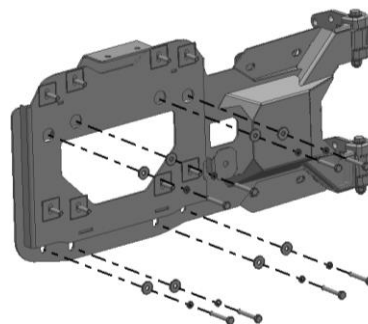

## PROCEDURE

### STEP 12

With assistance, pick up the assembly and carefully slide the hinges into the right side of the cargo area. Reuse the factory hex bolts to attach the hinges to the vehicle. Slowly close the tail gate and check the alignment.

### STEP 13

Reinstall the right side plastic cover and attach the check rod door stop.

### STEP 14

Attach the spare tire carrier assembly to the Bolt Plates with:  
(8) 8mm (16 OD) Flat Washers  
(8) 8mm Nylon Lock Nuts

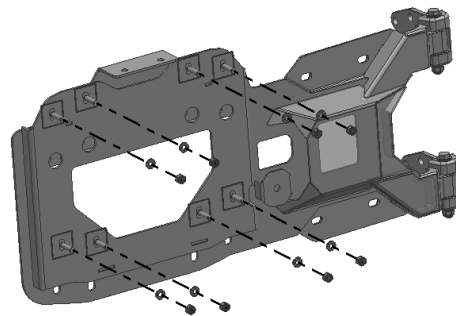

### STEP 15

Level and adjust the spare tire carrier and tighten the hardware. Attach the rubber bumper removed in **STEP 5** to the center location on the Spare Tire Mount.



## PROCEDURE

### STEP 16A

Reinstall the spare tire onto the tire carrier.

Depending on tire and rim width, size and wheel offset, it may be necessary to raise the CHMSL, (3<sup>rd</sup> brake light) above the factory mount.

### STEP 16B

Raise light with factory light bracket and tire support

- Remove (4) screws attaching bottom of light mount to top of spare tire mount.
- Slide factory bracket up and reuse (2) Screws to reattach to top hole in bracket only.
- Tighten hardware.

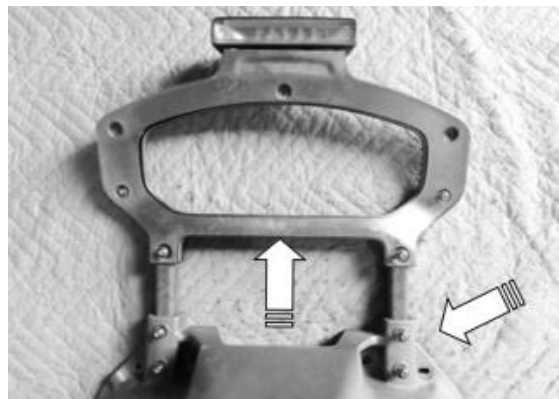

### STEP 16C

Raise light and increase clearance between top/back of spare tire and light bracket.

- Remove (4) screws attaching bottom of light mount to top of spare tire mount.
- Remove (7) screws from front of bracket to remove wire cover.
- Remove light and wire harness from top of factory light bracket.
- Attach Upper Bracket to Lower Bracket with (4) 6mm x 20mm Button Head Bolts (8) 6mm Flat Washers (4) 6mm Nylon Lock Nuts.

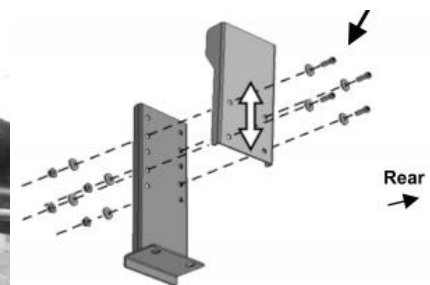
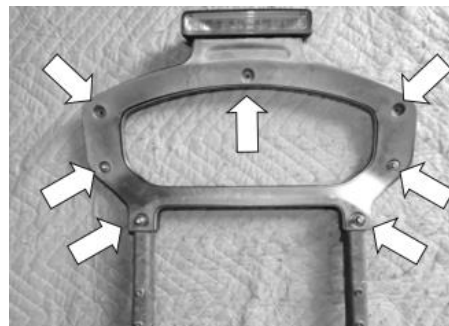

## PROCEDURE

### STEP 16D

- Attach light to top of Upper Light Bracket.
- Check height and light clearance above spare tire and adjust as necessary.
- Attach Light and Bracket assembly to top of Relocation Mount with the included (2) 10mm x 30mm Hex Bolt, (4) 10mm Flat Washers and (2) 10mm Nylon Lock Nuts.
- Run wire harness down backside of Upper and Lower Light Bracket assembly.
- Tighten hardware.

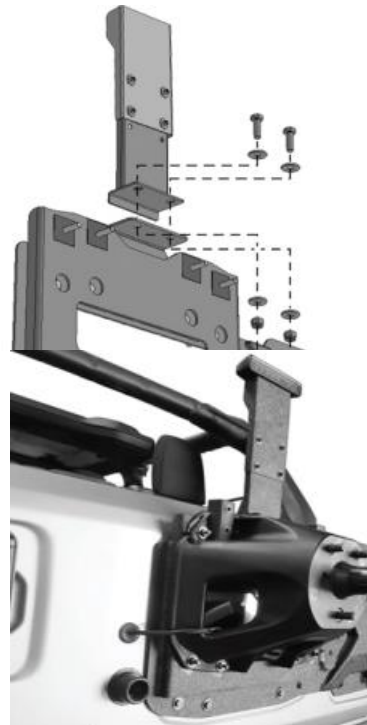

### STEP 17

Remove spare tire. Push the camera and light harness through the hole in the tailgate and plug into factory harness

### STEP 18

Check tailgate, camera and light operation. Adjust as necessary and tighten all hardware. Reinstall plastic cover on tailgate.