



**BLACK HORSE
OFF ROAD®**

TEL: 1-866-XANATOS

INSTALLATION INSTRUCTIONS

**TUBE STYLE REAR FENDER FLARE
20-24 JEEP GLADIATOR
PART#TFFG20R**

PARTS LIST:

1	Driver/Left Rear Fender	16	6mm Lock Washers
1	Passenger/Right Rear Fender	16	6mm x 12mm x 1.6mm Flat Washers
1	6mm Threaded Insert Tool	14	6mm Flange Nuts
2	6mm Threaded Inserts	1	4mm Hex Wrench
16	6mm x 25mm Button Head Bolts		

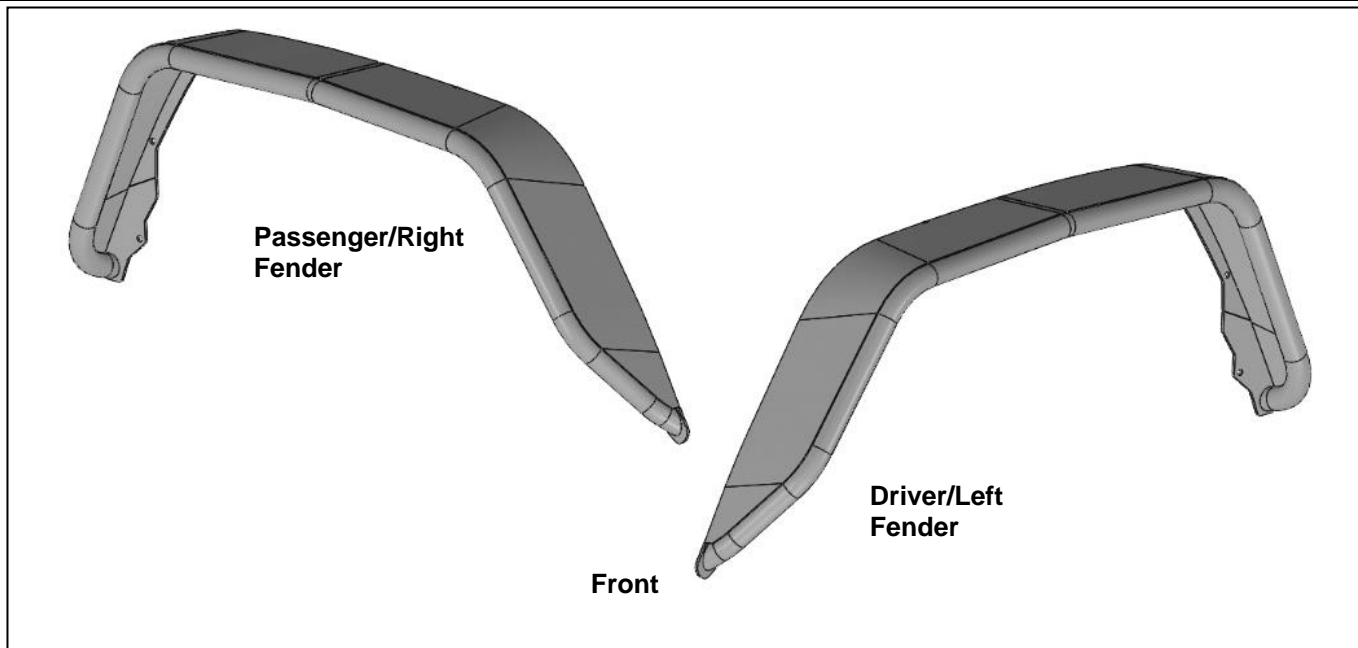

PROCEDURE:

REMOVE CONTENTS FROM BOX. VERIFY ALL PARTS ARE PRESENT. READ INSTRUCTIONS CAREFULLY. CUTTING AND MODIFICATION IS REQUIRED TO REINSTALL THE PLASTIC FENDER LINER. DRILLING IS REQUIRED. ASSISTANCE IS RECOMMENDED.

1. Start installation on the Driver/Left side of the vehicle. Release the plastic clips and remove any hardware attaching the liner to the outer edge and underside of the fender and the body, **(Figure 1)**. Remove the inner fender liner.
2. Next, firmly pull the fender straight outward from the body to pop the clips from the mounting holes, **(Figure 2)**. Remove any clips left attached to the body panel and move the fender to a smooth, clean surface.
3. Use an electric drill and 25/64" drill bit, (not included) to drill out the mounting hole in the front of the wheel well the body **(Figures 3 & 4)**. **VERY IMPORTANT:** Only drill through the outer sheet metal to enlarge the holes for a Threaded Insert, **do not drill completely through the body**.
 - a. Select the 6mm Threaded Insert Installation Tool and (1) 6mm Threaded Insert, **(Figure 6-A)**.
 - b. Screw the Insert onto the threaded end of the Insert Tool, **(Figure 6-A)**.
 - c. Firmly hold the Tool and push the Insert into one of the drilled holes, **(Figure 6-B)**.
 - d. Insert should fit snug into the drilled hole. Lightly tap the Tool and Insert into the hole with a small hammer if necessary.
 - e. Firmly hold the hex nut on the Insert Tool in place with a wrench and turn the hex bolt clockwise to tighten the bolt and expand the Insert in the hole **(Figure 6-C)**.
 - f. Once Insert is fully compressed and expanded, remove the Tool from the Insert. **WARNING:** Do not overtighten Insert or damage to the Insert may result.
4. With assistance, hold the Fender up in position. Attach the Fender to the previously installed Threaded Insert with (1) 6mm Button Head Bolts, (1) 6mm Lock Washers and (1) 6mm Flat Washers, **(Figure 7)**. Do not tighten hardware at this time.
5. Next, attach the Fender to the (7) remaining mounting locations with access to the back of the outer body panel. Attach the Fender to the (7) locations with (7) 6mm Button Head Bolts, (7) 6mm Lock

Washers, (7) 6mm Flat Washers and (7) 6mm Flange Nuts, **(Figures 5, 7—9)**. Do not tighten hardware at this time.

6. **With the fender in place, determine if plastic fender liner will be reinstalled**
 - a. Slide fender liner into position.
 - b. Trim the outer section from the liner. **NOTE:** Actual amount to remove from liner to be determined by installer. Leave as many mounting points on the plastic liner as possible.
 - c. Reinstall modified plastic fender liner if desired.
7. Adjust the position of the Fender and fully tighten all hardware.
8. Repeat **Steps 1—7** to attach the Passenger/Right Fender.
9. Do periodic inspections to the installation to make sure that all hardware is secure and tight.

To protect your investment, Do not use any type of polish or wax that may contain abrasives that could damage the finish. Mild soap may be used to clean the Fenders.

Driver/Left Side Installation Pictured



(Fig 1) Release clips and all hardware attaching inner fender liner to outer fender (Passenger/Right side shown)

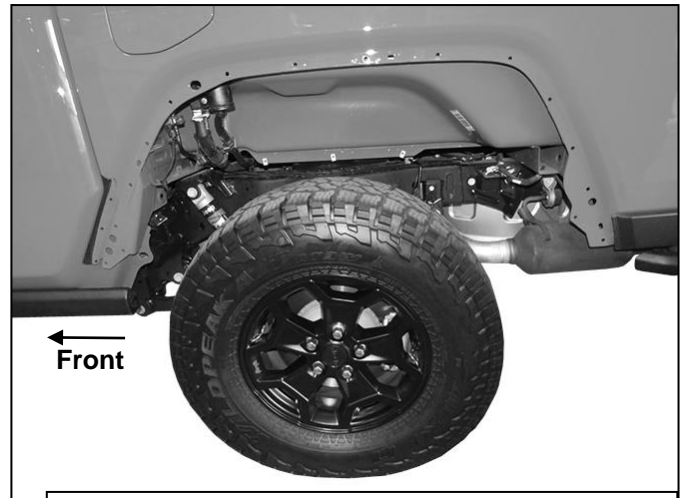

(Fig 2) Firmly pull fender straight out from vehicle. Remove any clips still attached to body

Driver/Left Side Installation Pictured

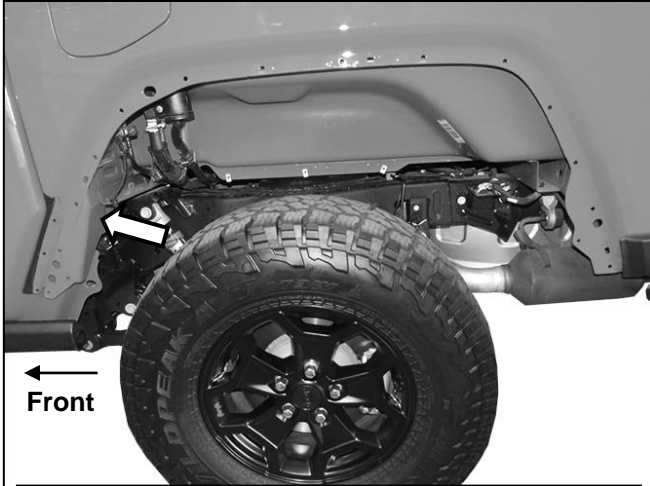

(Fig 3) Drill 25/64" hole in body panel at front location (arrow) NOTE: The mounting location cannot be accessed from between body panels

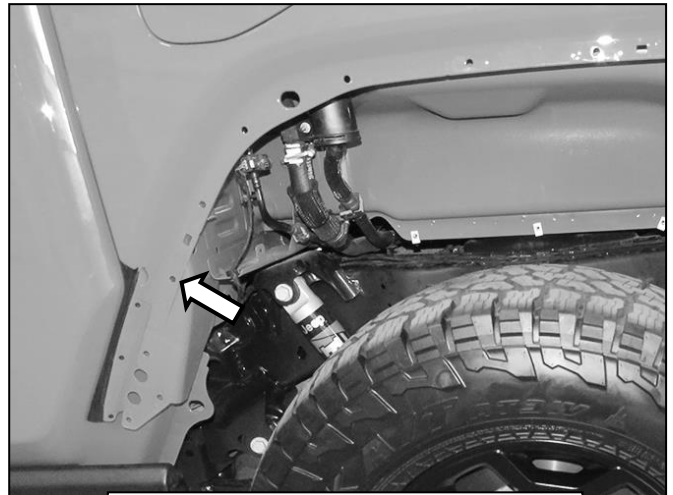

(Fig 4) Drill the hole in the front of the wheel well with a 25/64" drill bit

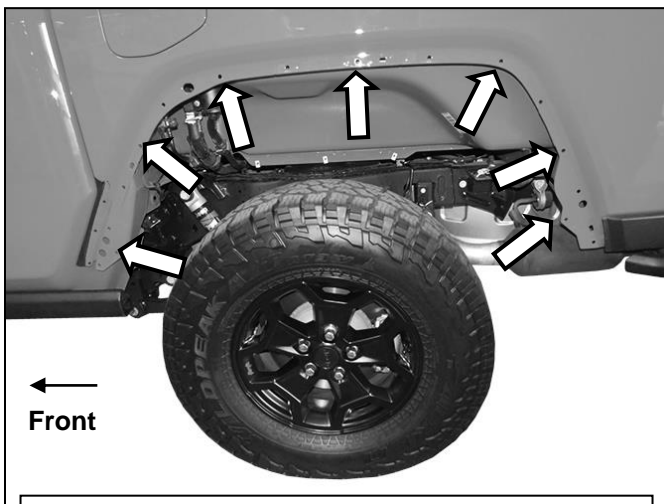

(Fig 5) Do not drill these (7) mounting locations. NOTE: The (7) mounting locations can be accessed from between body panels

Driver/Left Side Installation Pictured

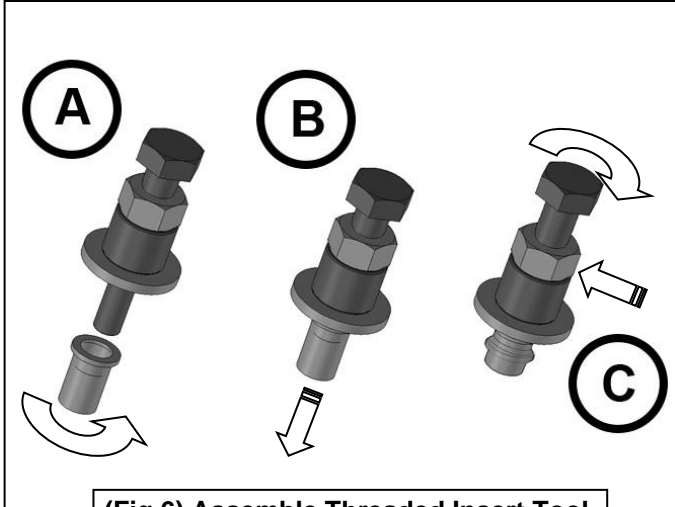

(Fig 6) Assemble Threaded Insert Tool

(6-A) Select Insert Tool and (1) Insert. Thread Insert onto end of Insert Tool. Hand tighten only, do not tighten hex bolt

(6-B) Firmly hold assembly and push Insert into drilled hole.

(6-C) Use a wrench (open or box end) to hold nut (arrow) to prevent nut and tool from turning. Hold Tool Assembly up tight in body panel. Turn hex bolt in Tool clockwise to expand insert in body panel. Remove Tool once Insert is fully tightened. Do not overtighten or Insert may be damaged.

- (3) 6mm Button Head Bolts
- (3) 6mm Lock Washers
- (3) 6mm Flat Washers
- (3) 6mm Flange Nuts

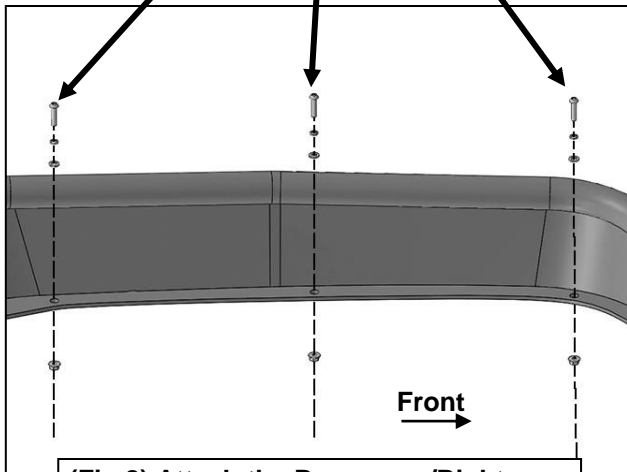

(Fig 8) Attach the Passenger/Right Fender to the top of the fender location

- (3) 6mm Button Head Bolts
- (3) 6mm Lock Washers
- (3) 6mm Flat Washers

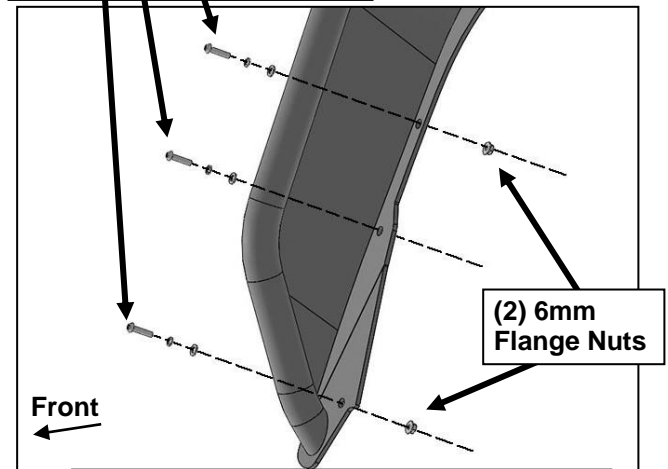

(Fig 7) Attach the Passenger/Right Fender to the front of the fender location

- (2) 6mm Button Head Bolts
- (2) 6mm Lock Washers
- (2) 6mm Flat Washers
- (2) 6mm Flange Nuts

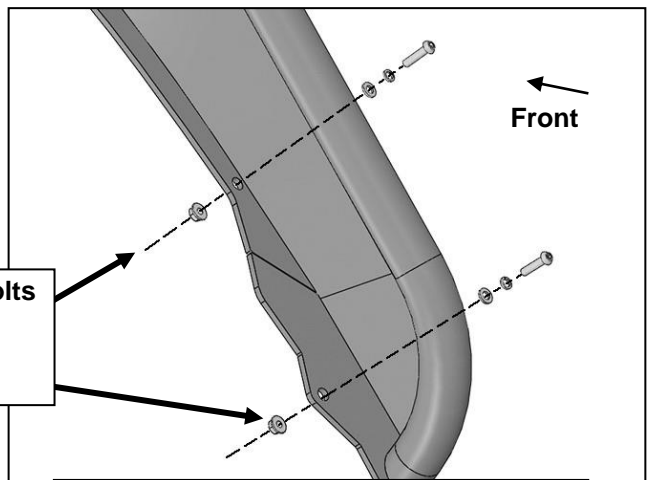

(Fig 9) Attach the Passenger/Right Fender to the rear of the fender location