



**BLACK HORSE
OFF ROAD®**

TEL: 1-866-XANATOS

INSTALLATION INSTRUCTIONS

**1PAIR FRONT FENDER LINERS
18-24 JEEP WRANGLER JL 2 AND 4-DOOR
(Incl. 20-24 diesel engine & 21-24 4xe)
20-24 JEEP GLADIATOR
PART#TFFJL4F**

1PAIR FRONT FENDER LINERS
18-24 JEEP WRANGLER JL 2 AND 4-DOOR (Incl. 20-24 diesel engine & 21-24 4xe)
20-24 JEEP GLADIATOR

PARTS LIST:

1	Driver/Left Fender Liner	2	6-1.0mm Clip Nuts
1	Passenger/Right Fender Liner	16	6-1.0mm x 20mm Button Head Combo Bolts
2	Front Lower "U" Support Brackets	4	6-1.0mm x 15mm Button Head Bolts
2	Front Upper Short "L" Support Bracket	2	6mm x 18mm x 1.6mm Flat Washers
2	Rear Upper Long "L" Support Bracket	8	6mm x 12mm x 1.6mm Flat Washers
1	Driver/left Rear Lower "Z" Support Bracket	4	6mm Lock Washers
1	Passenger/right Lower "Z" Support Bracket	6	6mm Hex Nuts
		1	4mm Wrench

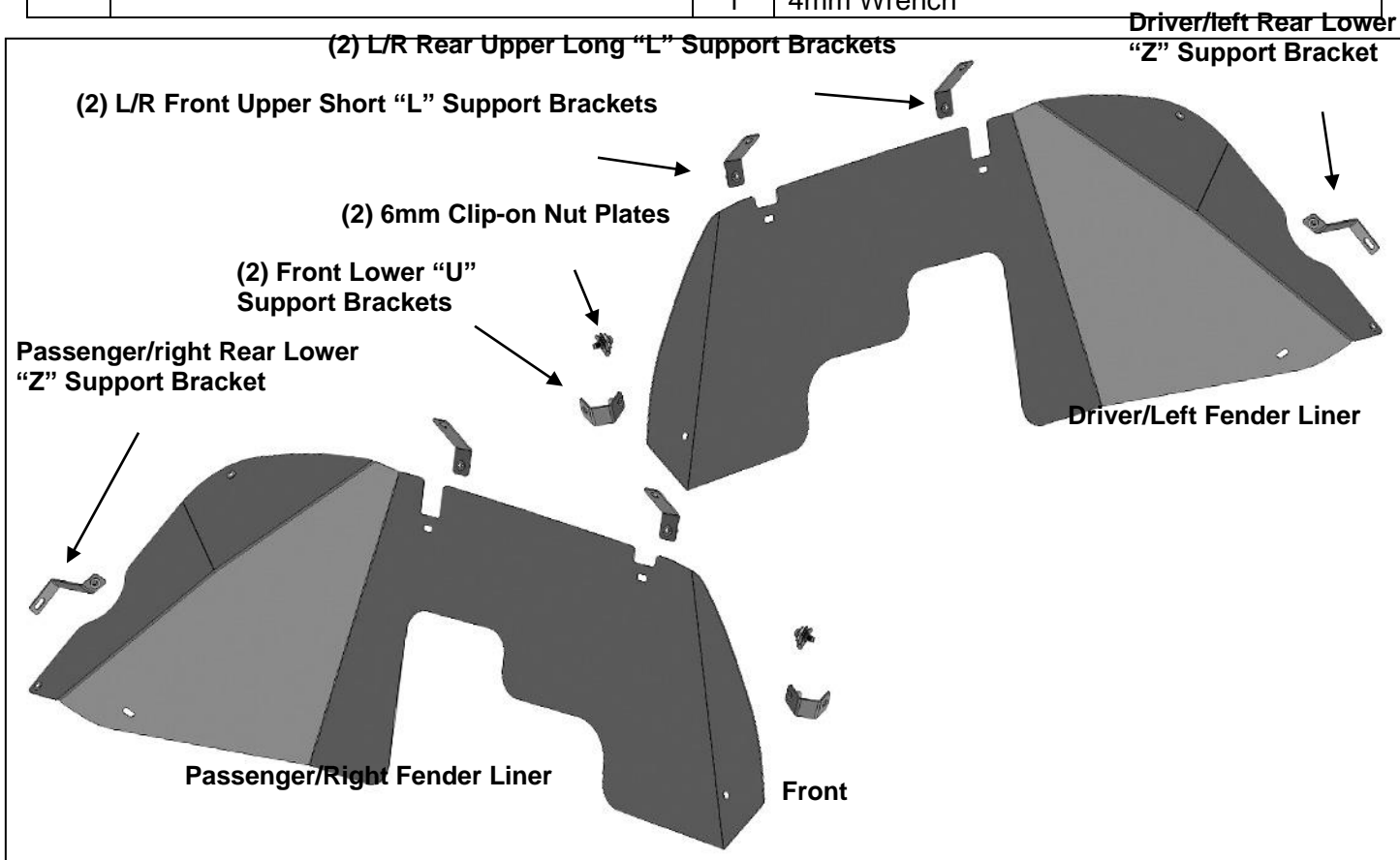

PROCEDURE:

REMOVE CONTENTS FROM BOX. VERIFY ALL PARTS ARE PRESENT. READ INSTRUCTIONS CAREFULLY. ASSISTANCE IS RECOMMENDED.

1. Start installation on the passenger/right side of the vehicle. Locate the front body mount, **(Figure 1)**. Slide (1) 6mm Clip Nut onto the steel mount. Line up the Nut with the rear facing hole in the side of the steel mount, **(Figures 1 & 2)**.
2. Select (1) Front Lower "U" Support Bracket. Attach the Bracket to the Clip Nut with (1) 6mm Combo Bolt, **(Figures 2 & 3)**. Rotate the Bracket so that the Threaded Nut is facing outward. Snug but do not fully tighten at this time.
3. Next, locate the (2) fender supports attached to the side of the body panel, **(Figure 4)**. Select (1) Front Upper Short "L" Support Bracket, **(Figure 5)**. Attach the Bracket to the hole in the bottom of the front support with (1) 6mm x 15mm Button Head Bolt, (2) 6mm x 12mm Small Flat Washers, (1) 6mm Lock Washer and (1) 6mm Hex Nut, **(Figure 9)**. Leave loose.
4. Move to the rear fender support. Repeat **Step 2** to attach the longer Rear Upper "L" Support Bracket to the rear fender support, **(Figures 5 & 10)**. Do not fully tighten hardware.

1PAIR FRONT FENDER LINERS
18-24 JEEP WRANGLER JL 2 AND 4-DOOR (Incl. 20-24 diesel engine & 21-24 4xe)
20-24 JEEP GLADIATOR

5. Continue along the body to the rear mounting location for the outer fender. Remove the plastic clip attaching the top of the cover if attached, **(Figure 6)**. Select the passenger/right Rear Lower “Z” Support Bracket, **(Figure 7)**. Attach the Support Bracket over the upper mounting hole in the cover or directly to the tab on the body with the included (1) 6mm Combo Bolt, (1) 6mm x 18mm Large Flat Washer and (1) 6mm Hex Nut, **(Figures 7, 14 & 15)**. Leave loose.
6. Select the passenger/right Fender Liner. Insert the Fender Liner into position. **NOTE:** It may be easier to install the Fender Liner with the vehicle raised up and/or front tire removed. Insert the back portion of the Fender Liner behind the body panel.
7. Attach the Fender Liner to the (2) Top Support Brackets with the included (2) 6mm Combo Bolts, **(Figures 8—10)**. Do not fully tighten hardware.
8. Line up the threaded insert in the Lower Front “U” Support Bracket with the back of the mounting hole in the forward end of the Liner. Attach the front of the Fender Liner to the Bracket, (see **Step 1**), with (1) 6mm Combo Bolt, **(Figures 11 & 12)**. Do not fully tighten hardware.
9. Locate the top rear mounting location on the Fender Liner and body panel. Line up the threaded insert in the Liner with the hole in the body panel. Attach the Liner to the body panel with (1) 6mm Combo Bolt, **(Figure 13)**. Do not tighten hardware.
10. Move to the rear mounting location. Line up the threaded insert in the Liner with the mounting hole in the body and fender. Insert (1) Combo Bolt through the fender, the body and into the threaded insert in the Liner, **(Figures 14 & 15)**.
11. Attach the Liner to the “Z” Support Bracket with (1) 6mm Combo Bolt, **(Figures 14 & 15)**.
12. Adjust the location of all Brackets and the Liner then fully tighten first the mounting hardware for the Brackets, then tighten all hardware attaching the Fender Liner. **DO NOT** fully tighten fender liner hardware until after all Brackets have been adjusted and fully tightened.
13. Repeat **Steps 1—12** for driver/left side Fender Liner installation.
14. Do periodic inspections to the installation to make sure that all hardware is secure and tight.

To protect your investment, Do not use any type of polish or wax that may contain abrasives that could damage the finish. Mild soap may be used to clean the Fender Liners.

Passenger/right Side Installation Pictured

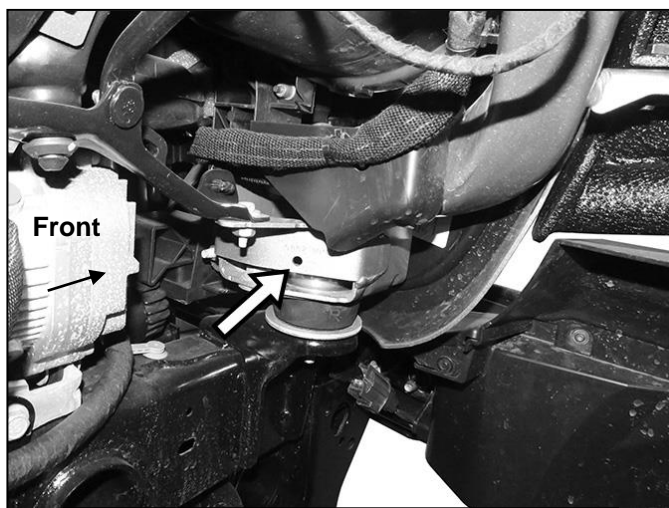

(Fig 1) Locate mounting location on passenger/right front body mount (arrow)

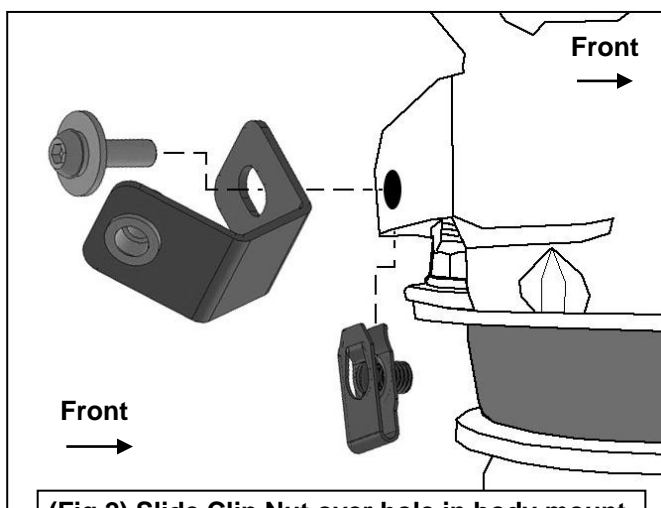

(Fig 2) Slide Clip Nut over hole in body mount. Attach Front Lower “U” Support Bracket to Clip Nut (passenger/right side pictured)

1PAIR FRONT FENDER LINERS
18-24 JEEP WRANGLER JL 2 AND 4-DOOR (Incl. 20-24 diesel engine & 21-24 4xe)
20-24 JEEP GLADIATOR

Passenger/right Side Installation Pictured

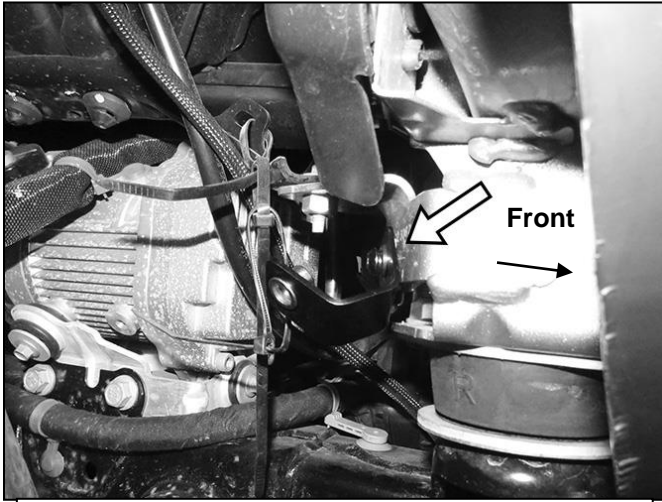

(Fig 3) Attach Front Lower "U" Support Bracket to Clip Nut with (1) 6mm Combo Bolt (arrow)

- (2) 6mm x 15mm Button Head Bolts
- (4) 6mm x 12mm Flat Washers
- (2) 6mm Lock Washers
- (2) 6mm Hex Nuts

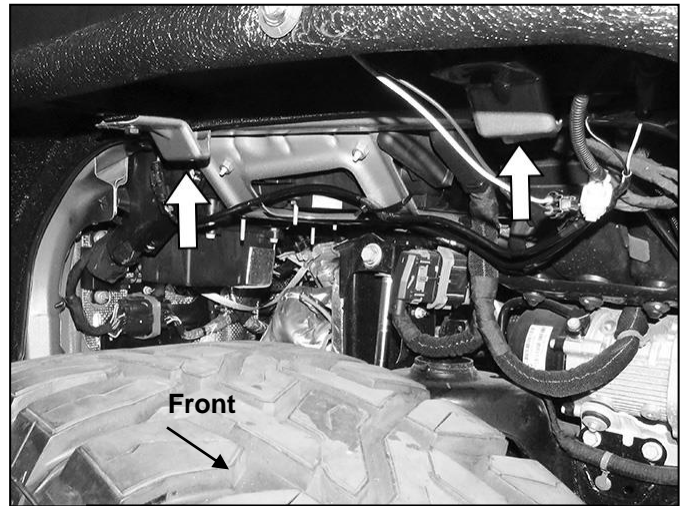

(Fig 4) Locate top mounting locations on bottom of fender supports (arrows)

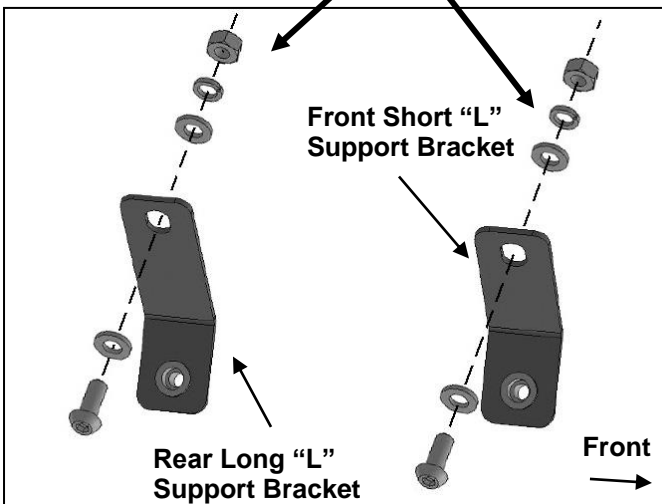

(Fig 5) Attach Top Support Brackets to bottom of fender supports (Fig 4)

Temporarily remove bolt attaching fender to lower body panel

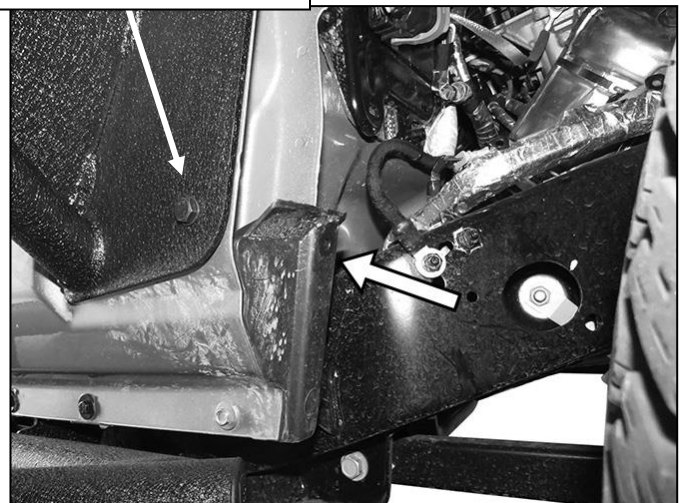

(Fig 6) Passenger/right mounting location for Rear "Z" Support Bracket. Remove plastic cover if desired. Bracket attaches to top mounting tab for cover (arrow)

1PAIR FRONT FENDER LINERS
18-24 JEEP WRANGLER JL 2 AND 4-DOOR (Incl. 20-24 diesel engine & 21-24 4xe)
20-24 JEEP GLADIATOR

Passenger/right Side Installation Pictured

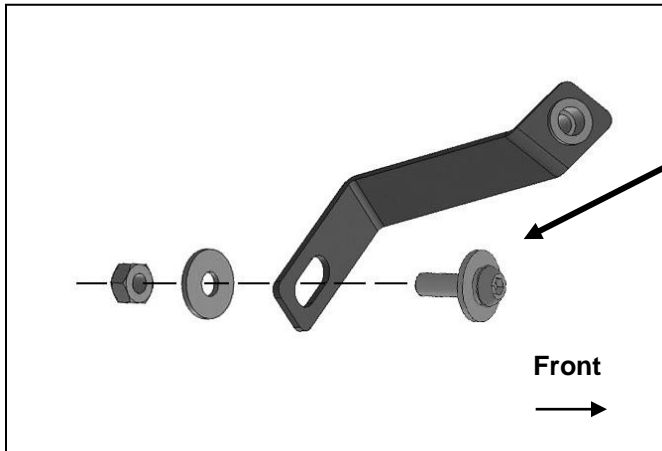

6mm Combo Bolt
 6mm x 18mm Flat Washer
 6mm Hex Nut

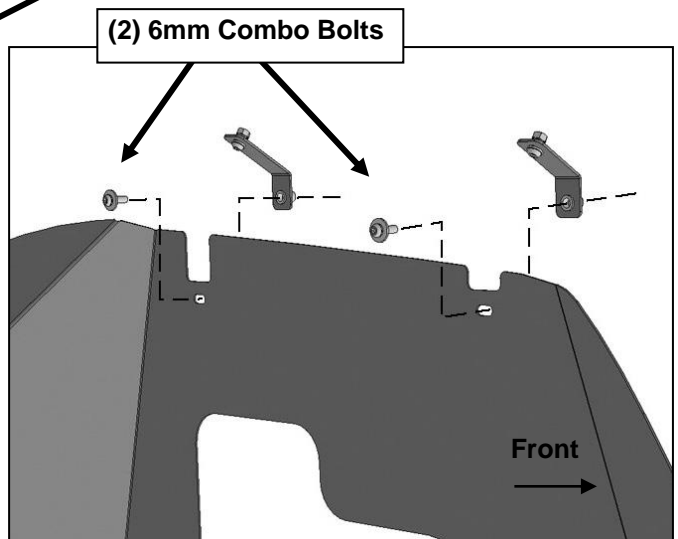

(2) 6mm Combo Bolts

(Fig 7) Attach passenger/right rear "Z" Support Bracket to upper mounting tab on body (Fig 6)

(Fig 8) Attach top of Fender Liner to Front and Rear Top Support Brackets

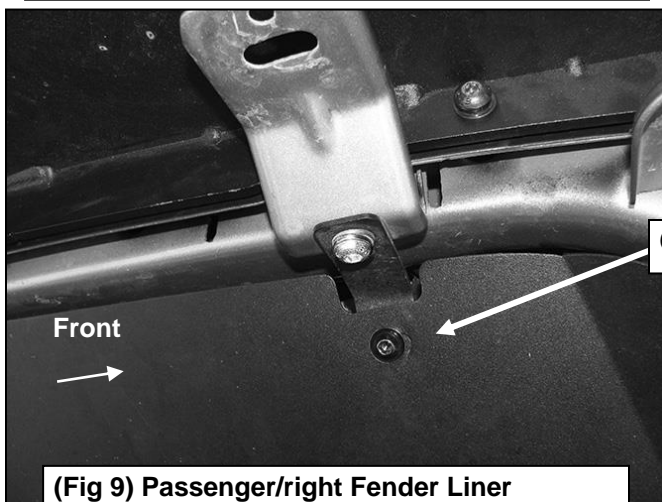

6mm Combo Bolt

6mm Combo Bolt

(Fig 9) Passenger/right Fender Liner attached to Top Front "L" Support Bracket

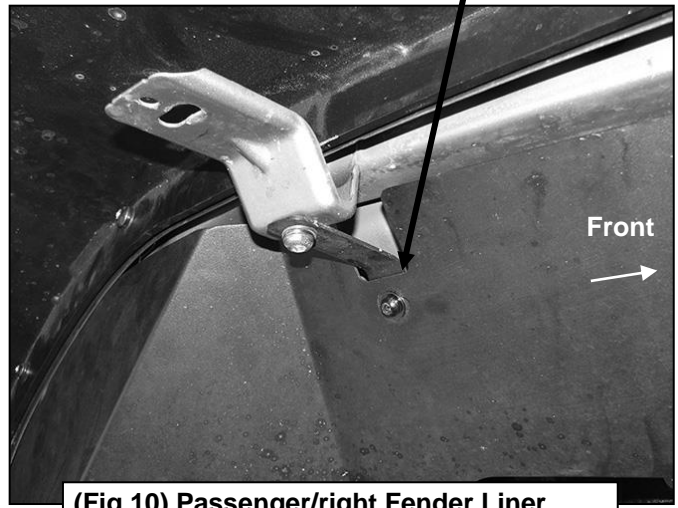

(Fig 10) Passenger/right Fender Liner attached to Top Rear "L" Support Bracket

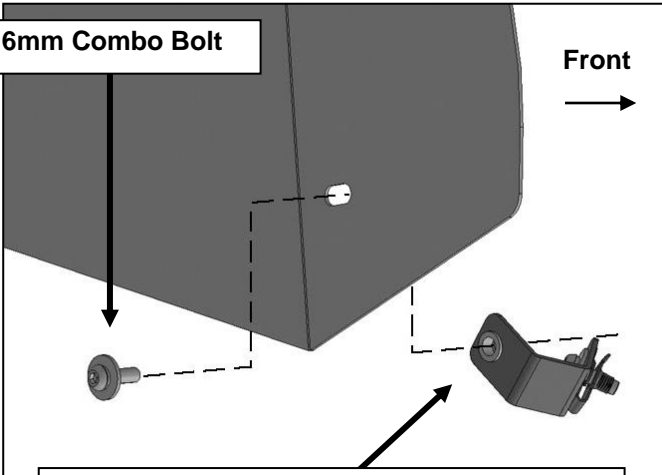

6mm Combo Bolt

(Fig 11) Attach front of Fender Liner to Front Lower "U" Support Bracket (Fig 2 & 3)

1PAIR FRONT FENDER LINERS
18-24 JEEP WRANGLER JL 2 AND 4-DOOR (Incl. 20-24 diesel engine & 21-24 4xe)
20-24 JEEP GLADIATOR

Passenger/right Side Installation Pictured

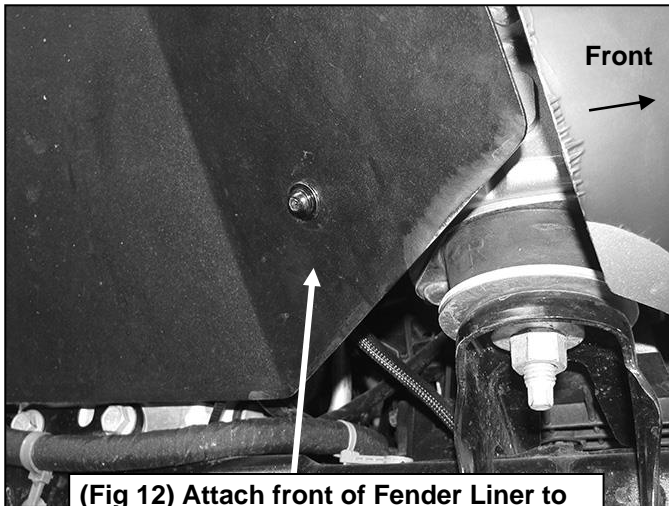

(Fig 12) Attach front of Fender Liner to Front Lower Support Bracket (Fig 2 & 3)

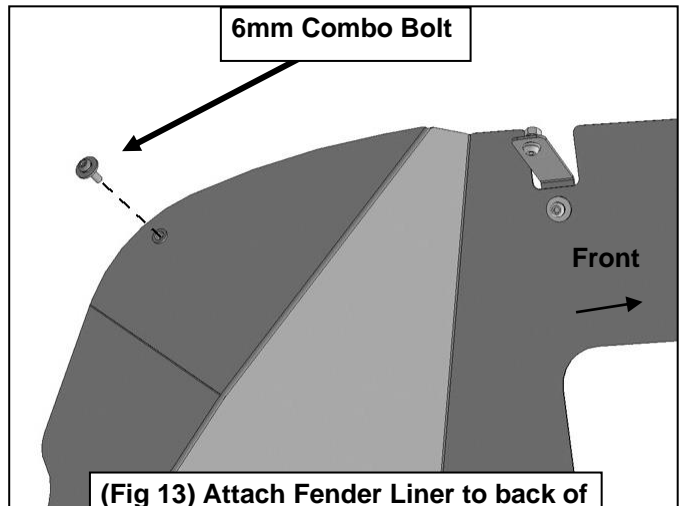

(Fig 13) Attach Fender Liner to back of top rear mounting location on body

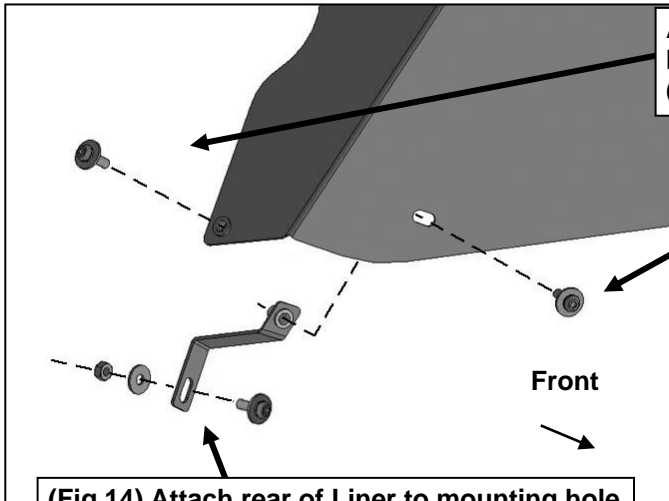

(Fig 14) Attach rear of Liner to mounting hole for fender and to "Z" Support Bracket (Fig 7)

Attach Liner to back of body panel and fender (1) 6mm Combo Bolt

6mm Combo Bolts



(Fig 15) Attach rear of Fender Liner to "Z" Support Bracket (Fig 7). Attach Liner to back of body panel and fender with the fender hardware or the included (1) 6mm Combo Bolt if long enough

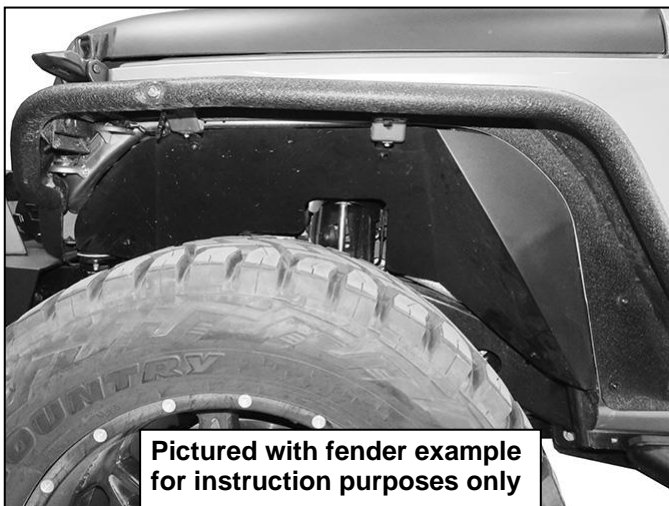

Pictured with fender example for instruction purposes only