



TEL: 1-866-XANATOS

INSTALLATION INSTRUCTIONS

**EPIC RUNNING BOARD
09-18 DODGE RAM 1500 (INCL. 19-21 RAM 1500 CLASSIC)
10-21 DODGE RAM 25-5500 CREW CAB
(INCL. CHASSIS CAB DIESEL MODELS)**

PART# E0685

PARTS LIST:

2	SE5 Sidebars	24	8mm Lock Washers
2	Driver Front/ Passenger Rear Mounting Brackets	24	8mm x 24mm OD x 2mm Flat Washers
2	Driver Rear/ Passenger Front Mounting Brackets	18	8mm Hex Nuts
1	Driver/Left Center Mounting Bracket	6	8mm Plastic Retainers
1	Passenger/Right Center Mounting Bracket	10	6mm x 25mm Button Head Bolts
6	Plastic Covers	20	6mm x 18mm OD x 1.6mm Flat Washers
12	Plastic Clips	10	6mm Serrated Flange Nuts
6	8mm Bolt/Nut Plates	4	16mm x 60mm Spacer Plates
12	8mm x 30mm Hex Bolts	2	16mm x 34mm Spacer Plates
12	8mm x 20mm T-Bolts	1	4mm Hex Wrench

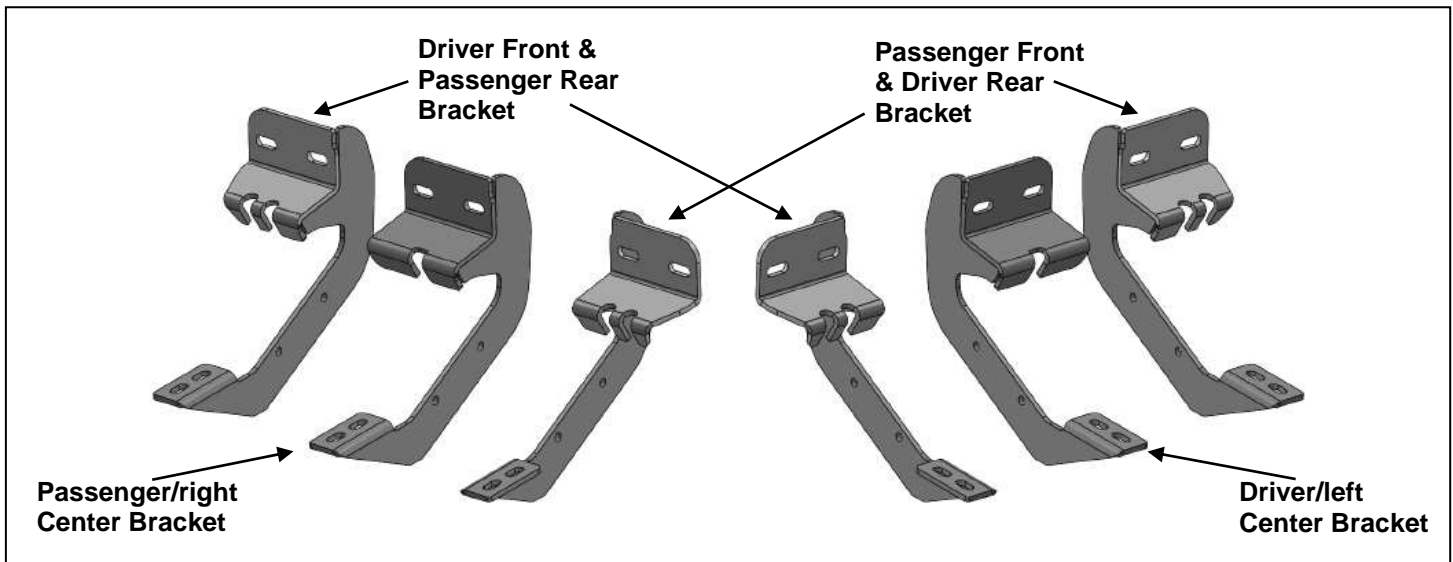

PROCEDURE:

1. REMOVE CONTENTS FROM BOX. VERIFY ALL PARTS ARE PRESENT. READ INSTRUCTIONS CAREFULLY BEFORE STARTING INSTALLATION. DRILLING MAY BE REQUIRED.
2. Starting at the driver front side of the vehicle, remove the sealing tape covering the factory holes in the side of the inner panel, **(Figure 1)**.
3. Determine the correct procedure to attach the driver/left side Front Bracket for your model/year:

Models without factory threaded inserts in body panel, (see Figure 1):

 - a. Select (1) 8mm Bolt-Nut Plate, **(Figure 2)**. Partially thread an 8mm Hex Bolt into the threaded nut on the Bolt-Nut Plate, **(Figure 3)**. Thread the Hex Bolt in until it is flush with the welded nut. Use the Hex Bolt as a handle and insert the Bolt-Nut Plate into the oval hole, **(Figure 4)**. Feed the threaded bolt on the Bolt-Nut Plate through one of the hex shaped factory holes.
 - b. Thread (1) 8mm Plastic Retainer onto the threaded end and down tight against the body panel, **(Figure 5)**. **NOTE:** The Plastic Retainer is designed to keep the Bolt-Nut Plate from falling into the body panel and to aid in Bracket installation.
 - c. Select the driver/left side Front Bracket. Attach the Bracket to the threaded end of the Bolt Plate with (1) 8mm Flat Washer, (1) 8mm Lock Washer and (1) 8mm Hex Nut, **(Figure 6)**.
 - d. Remove the 8mm Hex Bolt from the nut on the Bolt Plate from **Step 3a**. Rotate the Bolt on the Bolt-Nut Plate until the threaded nut lines up with the remaining hole in the Bracket and hex hole in the body panel, **(Figure 7)**. Attach the Bracket to the threaded nut with (1) 8mm x 30mm Hex Bolt, (1) 8mm Lock Washer and (1) 8mm Flat Washer, **(Figure 7)**. Do not tighten hardware.

Models with factory threaded inserts, (see Figure 8):

 - a. Attach the driver/left side Front Bracket to the threaded inserts with (2) 8mm x 30mm Hex Bolts, (2) 8mm Lock Washers and (2) 8mm Flat Washers, **(Figures 8 & 9)**. Leave hardware loose.

4. Next, attach the Bracket to the back of the pinch weld with (2) 6mm Button Head Bolts, (4) 6mm Flat Washers, (1) 16mm x 60mm Spacer Plate and (2) 6mm Flange Nuts, **(Figure 10)**. Do not fully tighten hardware at this time. **IMPORTANT:** 2009-12 models not equipped with factory holes will require drilling through the pinch weld to fully attach Bracket. Do not drill through pinch weld at this time, **(see Step 10)**.
5. Select (1) Plastic Cover. Attach the Cover to the Mounting Bracket with (2) Plastic Clips, **(Figure 11)**.
6. Move along the side of the body panel to the center mounting location, **(Figure 12)**. Repeat the appropriate **Steps 2—4** to install the Passenger/Right Center Bracket. **IMPORTANT:** The Center Mounting Bracket will use the 16mm x 34mm Spacer Plate.
7. Move to the rear location, **(Figure 13)**. Repeat the appropriate **Steps 2—4** to install the Driver/left side Rear Bracket.
8. Select (1) Sidebar. Insert (6) T-Bolts into the channels on the bottom of the Sidebar, (3) per channel, **(Figure 14)**. Attach the Sidebar to the Mounting Brackets with (6) 8mm Flat Washers, (6) 8mm Lock Washers and (6) 8mm Hex Nuts, **(Figure 15)**. Do not tighten hardware at this time.
9. Properly level and adjust the Running Board and fully tighten all hardware.
2009-12 models requiring drilling to attach Brackets to pinch weld:
 - a. Level the Running Board to the vehicle. Make sure all (3) Brackets are tight against the bottom of the body panel and tighten all mounting hardware.
 - b. Mark the location of the slots onto the pinch weld.
 - c. Temporarily remove the Running Board and the (3) Mounting Brackets. Drill (2) 1/4" holes through the pinch weld for each Bracket. **IMPORTANT:** Do not drill too close to the bottom edge of the pinch weld. Drill the holes in the center of the marked slots.
 - d. Repeat **Step 4** to attach the Brackets to the drilled holes in the pinch weld. Check for level then fully tighten all hardware.
10. Repeat **Steps 2—10** for Sidebar installation on the driver side.
11. Do periodic inspections to the installation to make sure that all hardware is secure and tight.

To protect your investment Do not use any type of polish or wax that may contain abrasives that could damage the finish. Mild soap may be used to clean the Sidebars.

Driver/left Side Installation Pictured

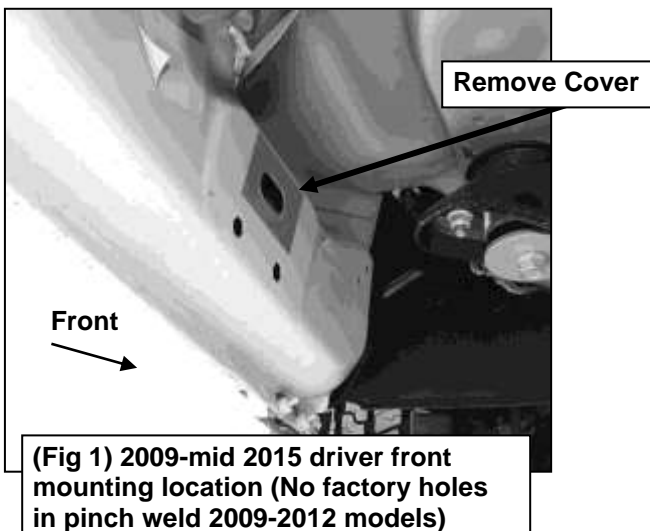

Driver/left Side Installation Pictured

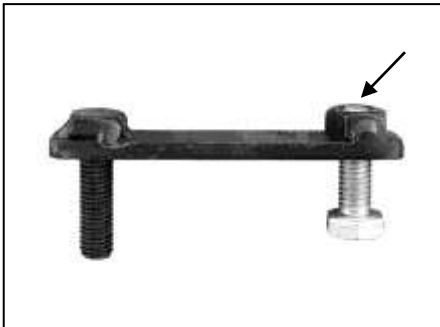

(Fig 3) Thread (1) 8mm Hex Bolt into the nut on the plate. Stop when bolt reaches end of nut as pictured

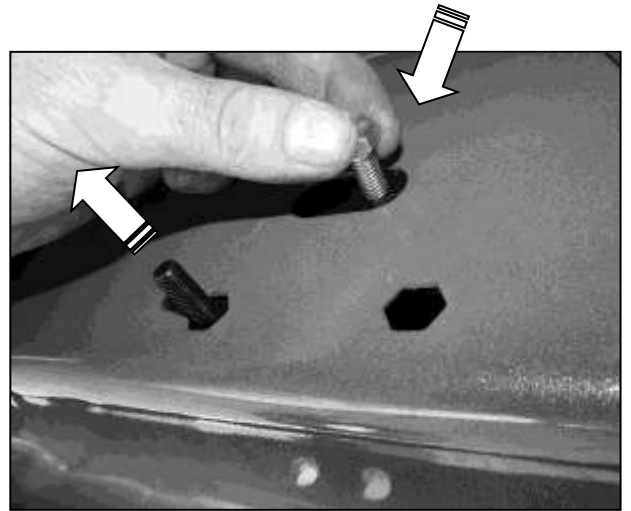

(Fig 4) Use the loose Hex Bolt as a handle. Insert the Bolt Plate into the oval hole and feed the threaded end out either factory hex shaped hole. **IMPORTANT:** Do not let go of the hex bolt until after Plastic Retainer has been threaded onto bolt (Fig 5)

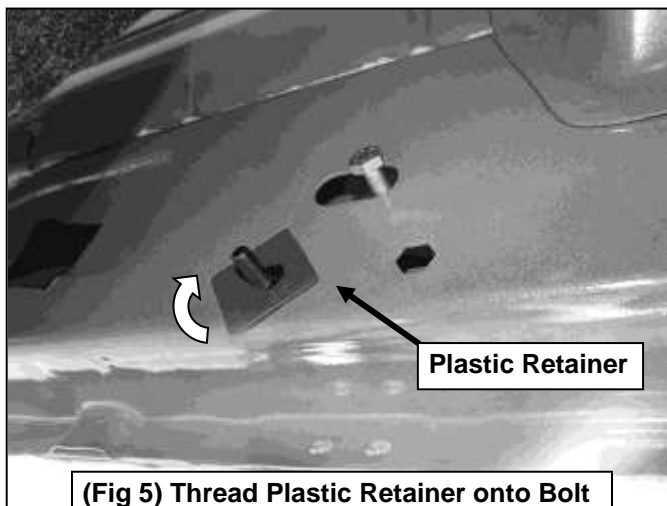

(Fig 5) Thread Plastic Retainer onto Bolt Plate to hold Bolt Plate in position.

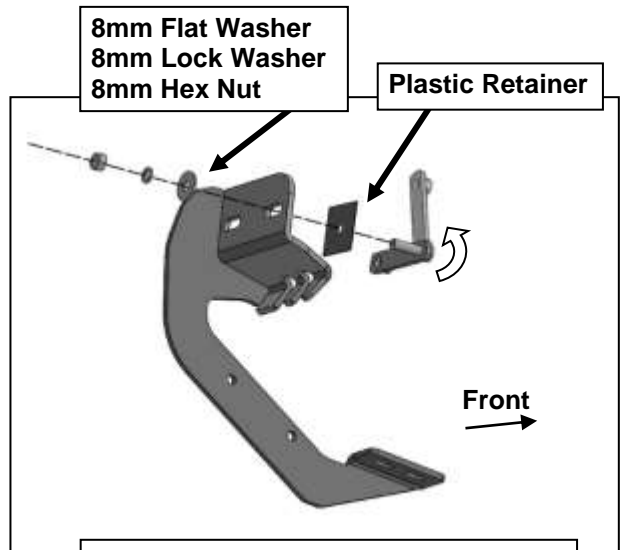

(Fig 6) Remove 8mm Hex Bolt. Rotate Bolt Plate to line up with remaining factory hex shaped hole

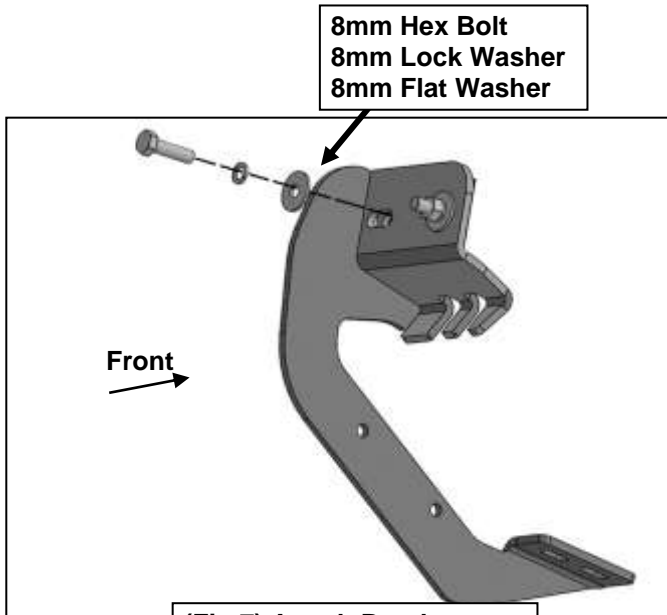

(Fig 7) Attach Bracket to threaded end of Bolt Plate

Driver/left Side Installation Pictured

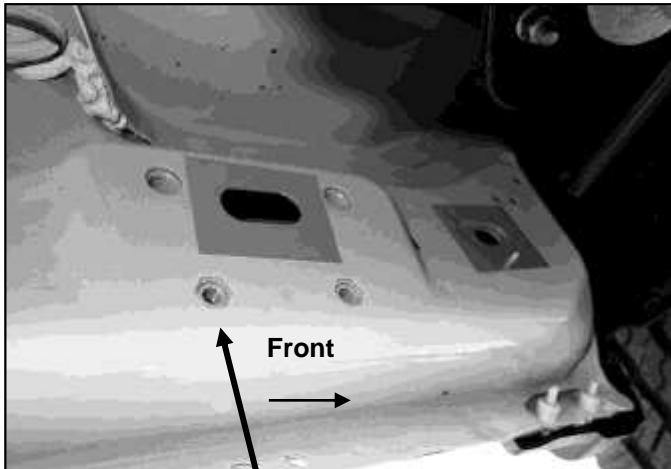

(Fig 8) Driver/left side front mid 2015-on (example of models with factory installed threaded inserts)

IMPORTANT: 2009-2012 models without holes in pinch weld will require drilling 1/4" holes through pinch weld to attach the bracket. Do complete installation of Running Boards first, level Running Board before drilling holes for bracket.

- (2) 8mm Hex Bolts
- (2) 8mm Lock Washers
- (2) 8mm Flat Washers

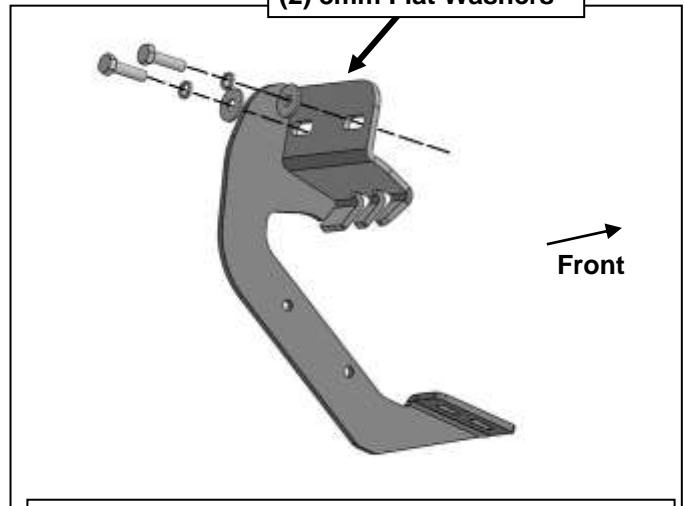

(Fig 9) Driver/left side front models with factory installed threaded inserts. Bolt Plate not required

- (2) 6mm Button Head Bolts
- (4) 6mm Flat Washers
- 16mm x 60mm Spacer Plate
- (2) 6mm Flange Nuts

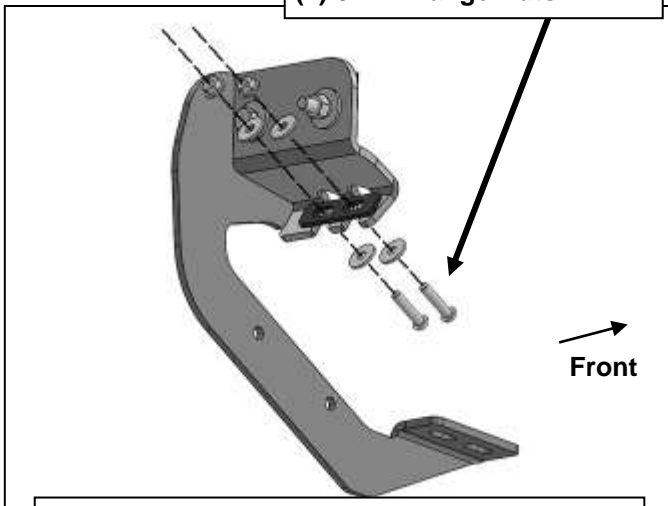

(Fig 10) Attach Bracket to back of pinch weld (models with factory holes in pinch weld only)

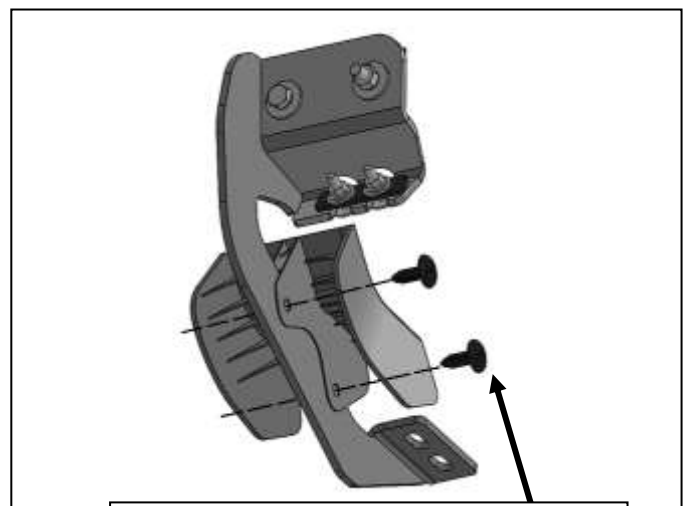

(Fig 11) Attach (1) Plastic Cover to the Mounting Bracket with (2) Plastic Clips

SE5 SIDEBAR
09-18 DODGE RAM 1500 (INCL. 19-21 RAM 1500 CLASSIC)
10-21 DODGE RAM 25-5500 CREW CAB (INCL. CHASSIS CAB DIESEL MODELS)
Driver/left Side Installation Pictured

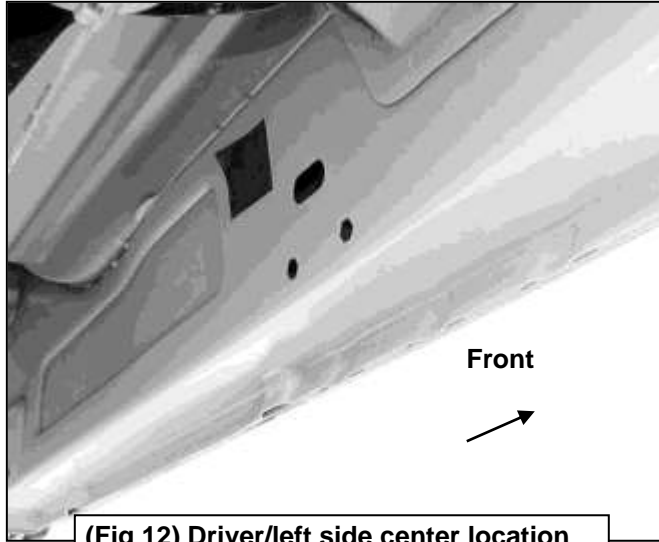

(Fig 12) Driver/left side center location

IMPORTANT: 2009-2012 models without holes in pinch weld will require drilling 1/4" holes through pinch weld to attach the bracket. Do complete installation of Running Boards first, level Running Board before drilling holes for bracket.

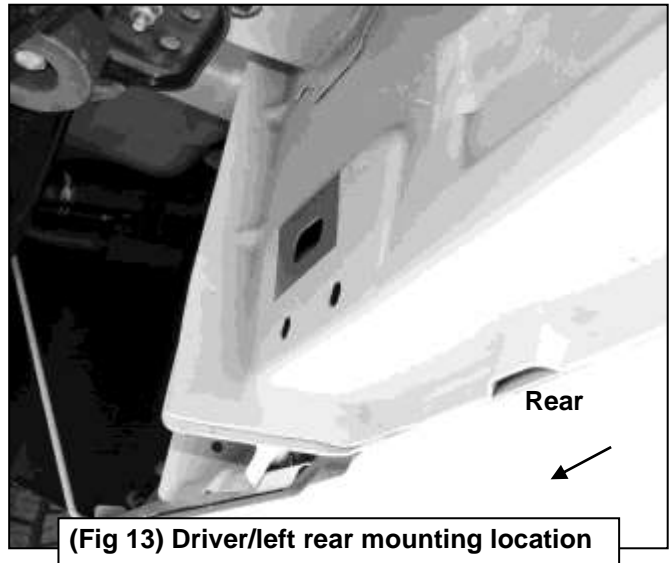

(Fig 13) Driver/left rear mounting location

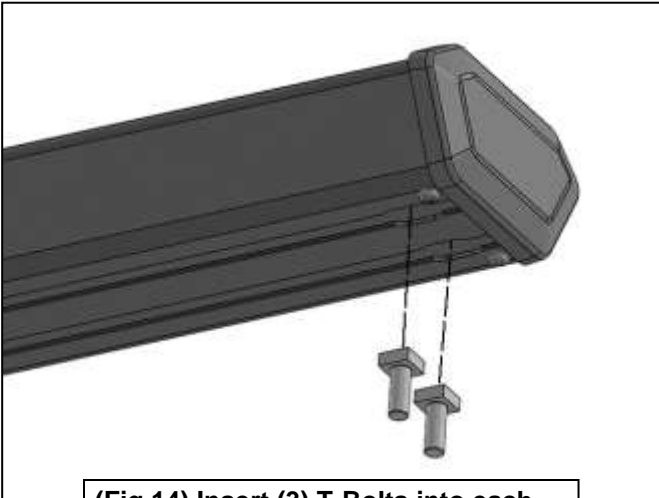

(Fig 14) Insert (3) T-Bolts into each channel on the bottom of the Sidebar

- (2) 8mm Flat Washers
- (2) 8mm Lock Washers
- (2) 8mm Hex Nuts

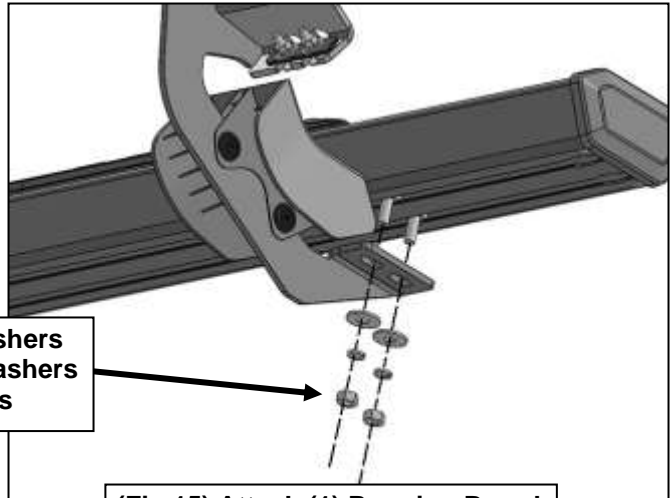

(Fig 15) Attach (1) Running Board to the Mounting Brackets