



INSTALLATION INSTRUCTIONS

PART # PIJ579

PARTS LIST:

1	Driver/Left Running Board	4	10mm Lock Washers
1	Passenger/Right Running Board	4	10mm x 50mm Hex Bolts
1	Driver/Left Front Mounting Bracket	1	10mm x 40mm Hex Bolt
1	Passenger/Right Front Mounting Bracket	1	10mm Hex Nut
1	Driver/Left Center Mounting Bracket	1	10mm Threaded Insert
1	Passenger/Right Center Mounting Bracket	1	10mm Insert Tool
1	Driver/Left Rear Mounting Bracket	28	6mm x 18mm OD x 1.6mm Flat Washers
1	Passenger/Right Rear Mounting Bracket	1	10mm Rivet Nut
4	12mm x 50mm Hex Bolts	22	6mm Lock Washers
4	12mm Lock Washers	22	6mm Hex Nuts
4	12mm x 32mm OD x 3mm Flat Washers	16	6mm x 20mm T-Bolts
1	10mm x 27mm OD x 3mm Flat Washer	6	6mm x 30mm Hex Bolts
4	10mm x 30mm OD x 2.5mm Flat Washers		

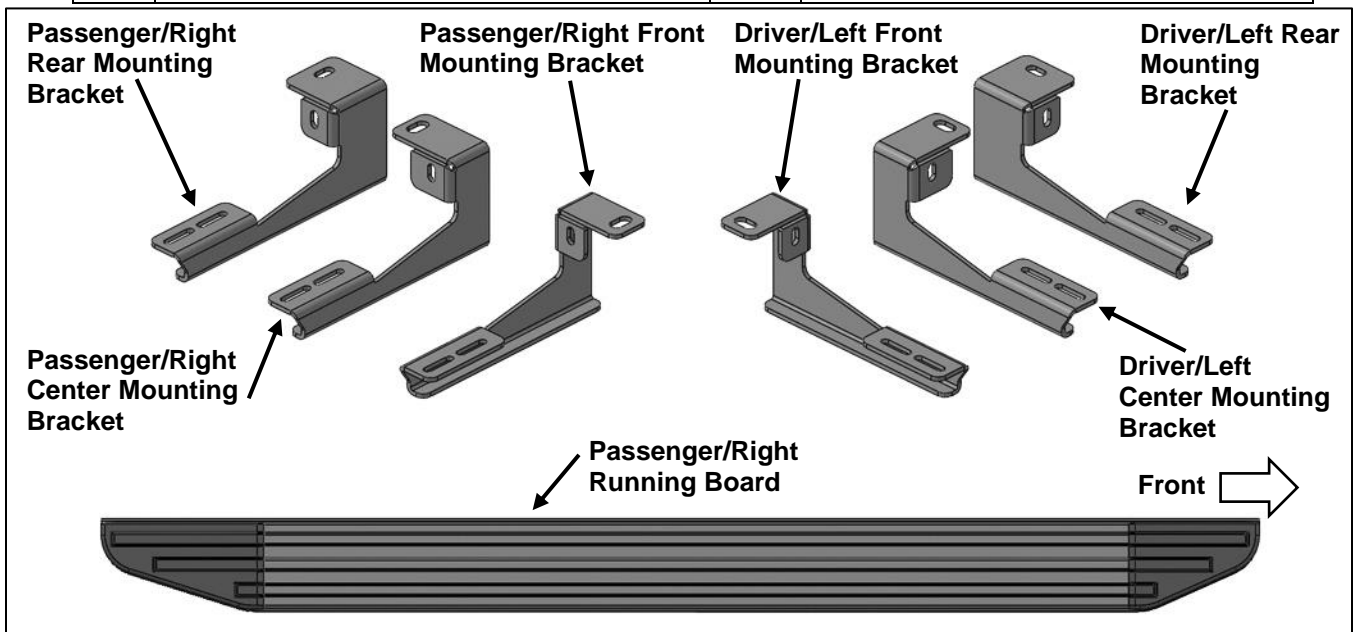

PROCEDURE:

- 1. REMOVE CONTENTS FROM BOX. VERIFY ALL PARTS ARE PRESENT. READ INSTRUCTIONS CAREFULLY. USE ILLUSTRATION TO IDENTIFY BRACKETS AND TYGER FURY STEPS.**
- Starting on the Driver/Left front of the vehicle, remove the cover on the bottom of the vehicle. Select the Driver/Left Front Mounting Bracket. Attach the Mounting Bracket to the threaded insert in the front location with (1) 12mm Hex Bolt, (1) 12mm Lock Washer and (1) 12mm Flat Washer, **(Figures 1 & 2)**. Do not tighten hardware.
- Attach the Mounting Bracket to the pinch trim with (1) 6mm Hex Bolt, (2) 6mm Flat Washer, (1) 6mm Lock Washer and (1) 6mm Hex Nut, **(Figure 3)**. Do not tighten hardware.
- Move along the body panel to the center mounting location, **(Figure 4)**. Select the Driver/Left Center Mounting Bracket. Repeat **Step 2** to install the Bracket, **(Figures 3 & 4)**. Do not tighten hardware.
- Continue to the rear mounting location in front of the rear tire, **(Figure 5)**. Select the Driver/Left Rear Mounting Bracket. Attach the Bracket to the threaded insert with (1) 10mm Hex Bolt, (1) 10mm Lock Washer and (1) 10mm Flat Washer, **(Figures 5 & 6)**. Do not tighten hardware. Repeat **Step 3** to attach the Bracket to the pinch trim.
- Select the Driver/Left Viewpoint Running Board. Insert (6) T-Bolts into the channels in the bottom of the Running Board, (3) per channel, **(Figure 7)**. Place the Running Board onto the Mounting Brackets and line up the T-Bolts. Attach the Running Board to the Mounting Brackets with (6) 6mm Flat Washers, (6) 6mm Lock Washers and (6) 6mm Hex Nuts, **(Figure 8)**. Do not tighten hardware.
- Level and adjust the Running Board and tighten all hardware.
- Move to the Passenger/Right side. Repeat **Steps 2,3 & 5** to attach the Passenger/Right Front and Rear Mounting Brackets.

9. Locate the center mounting location, **(Figure 9)**. Select the Passenger/Right Center Mounting Bracket. Hold the Bracket and line up to the hole in the pinch trim to the lower slot in the top of the Bracket. Mark where the top slot is located on the floor panel. Using a 1/2" drill bit, (not included) to drill through only the bottom layer of the floor panel.
 10. Select the 10mm Threaded Insert and the 10mm Insert Tool. Push the Tool and Insert assembly into the factory hole. **NOTE:** If Insert fits too tight, lightly tap it into place with a small hammer.
 11. Firmly hold the handle on the Tool and tighten the hex bolt in the Insert until it is fully collapsed and locked in place, **(Figures 10 & 11)**. **NOTE:** Do not over tighten the Insert or a pull out may occur. Once Insert is collapsed, remove the tool from the Insert.
 12. Attach the Passenger/Right Center Mounting Bracket to the Threaded insert with (1) 10mm Hex Bolt, (1) 10mm Lock Washer and (1) 10mm Flat Washer. Do not tighten hardware. Repeat **Step 3** to attach the Bracket to the pinch trim.
 13. Repeat **Steps 6 & 7** to attach the Passenger/Right Running Board. Do not tighten hardware.
 14. Level and adjust the Running Board and tighten all hardware.
 15. Do periodic inspections to the installation to make sure that all hardware is secure and tight.
- To protect your investment**, Do not use any type of polish or wax that may contain abrasives that could damage the finish. Mild soap may be used to clean the Running Boards.

Driver Side Installation Pictured

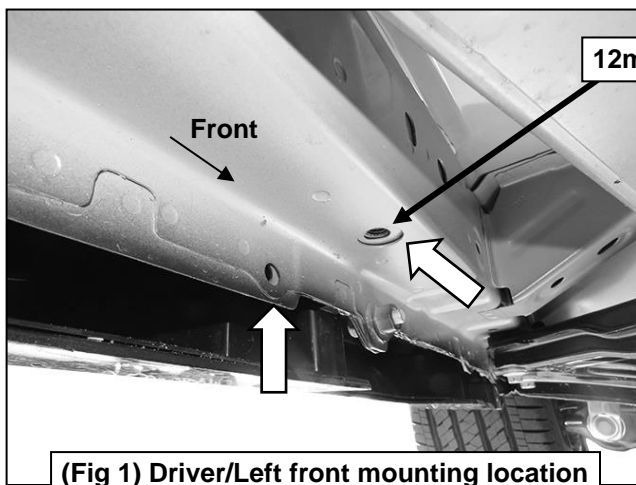

(Fig 1) Driver/Left front mounting location

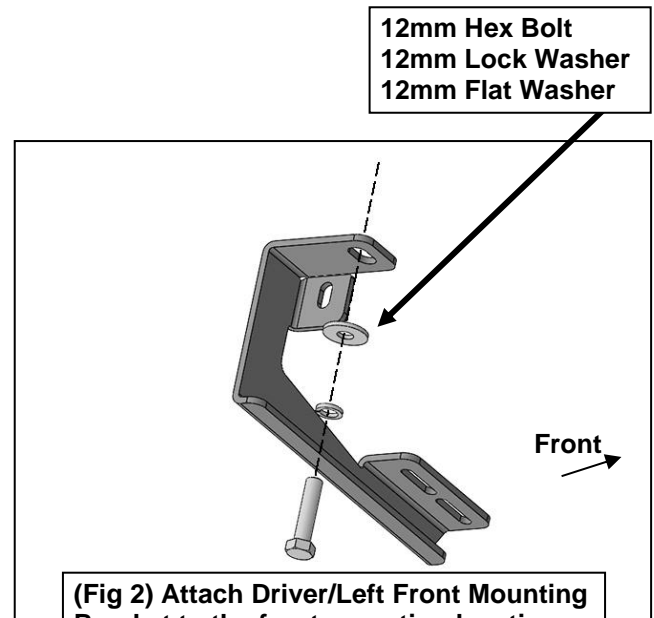

(Fig 2) Attach Driver/Left Front Mounting Bracket to the front mounting location

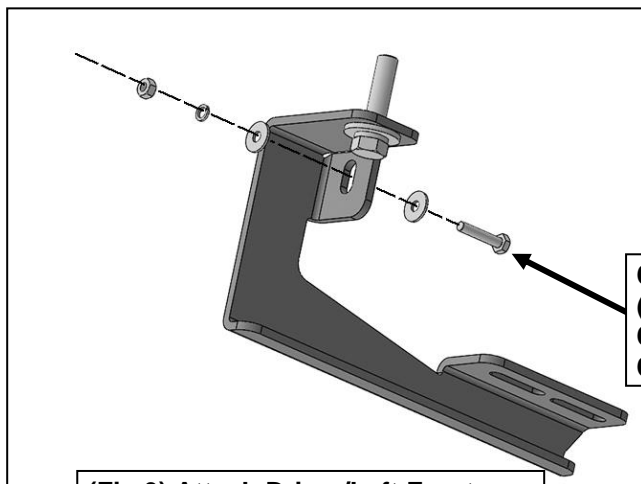

(Fig 3) Attach Driver/Left Front Mounting Bracket to the pinch trim

Driver Side Installation Pictured

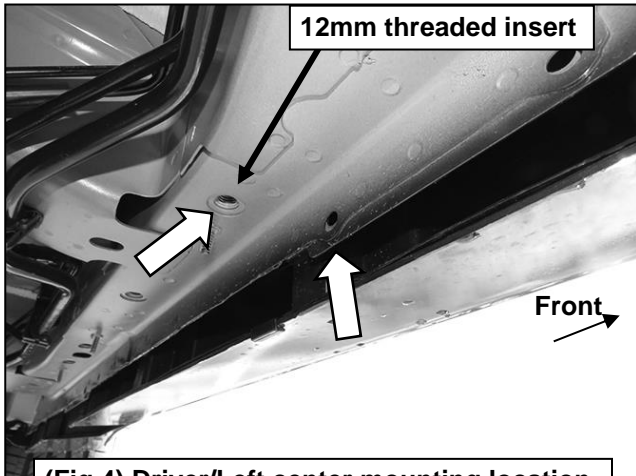

(Fig 4) Driver/Left center mounting location

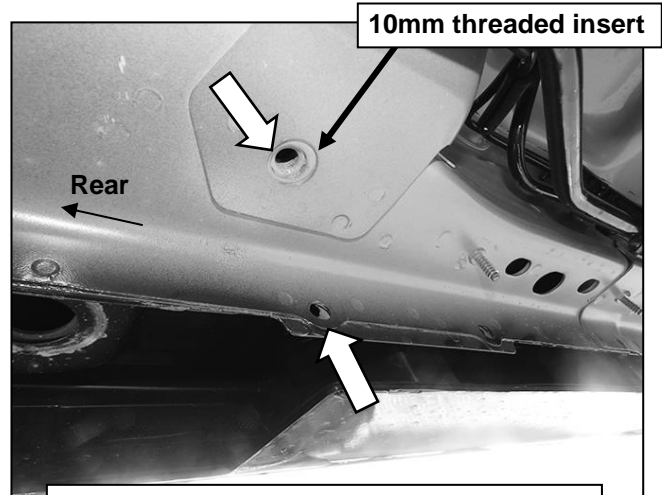

(Fig 5) Driver/Left rear mounting location. The threaded insert is smaller than the front and center locations

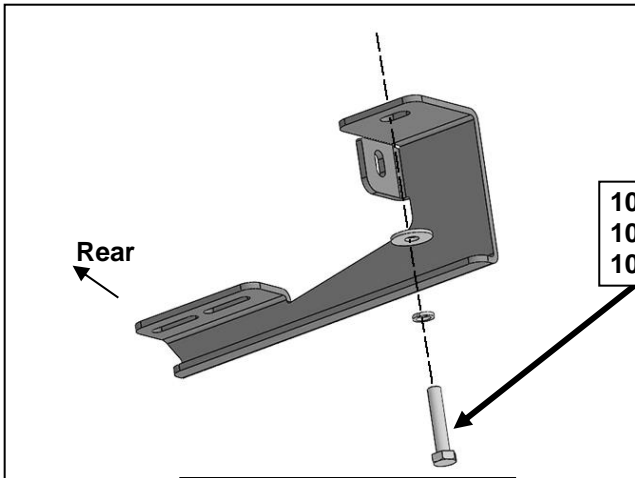

- 10mm Hex Bolt
- 10mm Lock Washer
- 10mm Flat Washer

(Fig 6) Attach Driver/Left Rear Mounting Bracket

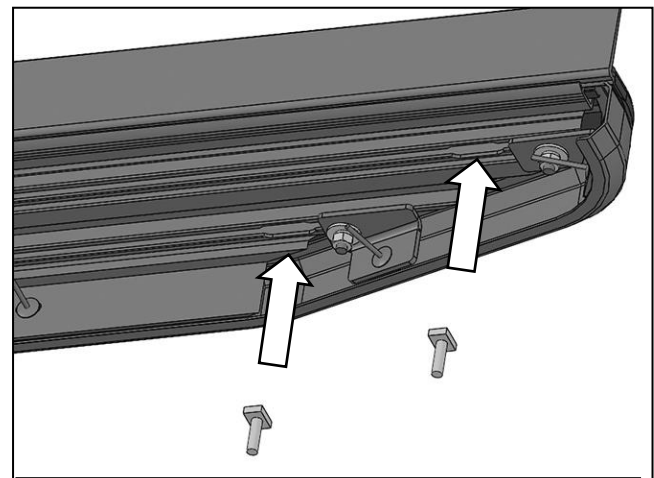

(Fig 7) Insert (6) 6mm T-Bolts into the channels under the Running Board, 3 per channel

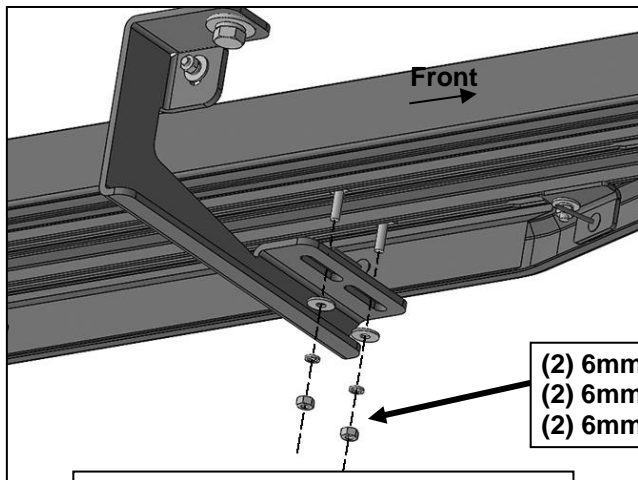

- (2) 6mm Flat Washers
- (2) 6mm Lock Washers
- (2) 6mm Hex Nuts

(Fig 8) Attach the Driver/Left Running Board to the Mounting Bracket

Passenger Side Installation Pictured

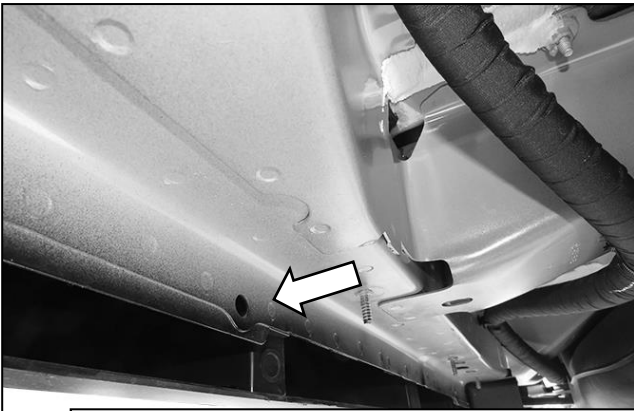

(Fig 9) Locate the Passenger/Right center mounting location. Line up the top of the Passenger/Right Center Mounting Bracket to the hole in the pinch trim. Mark the top slot for drilling. Use a 1/2" drill bit, not included

(10-A) Select Insert Tool and (1) Insert. Thread Insert onto end of Insert Tool. Hand tighten only, do not tighten hex bolt

(10-B) Firmly hold assembly and push Insert into drilled hole.

(10-C) Hold Tool Assembly up tight in body panel. Turn hex bolt in Tool clockwise to expand insert in body panel. Remove Tool once Insert is fully tightened. Do not overtighten or Insert may be damaged.

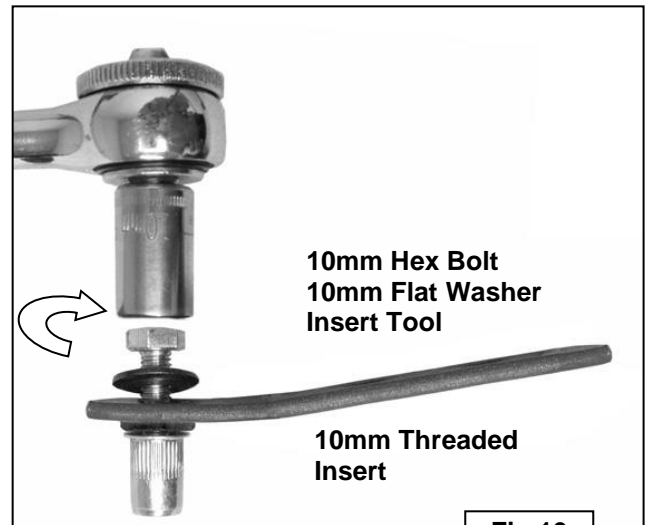
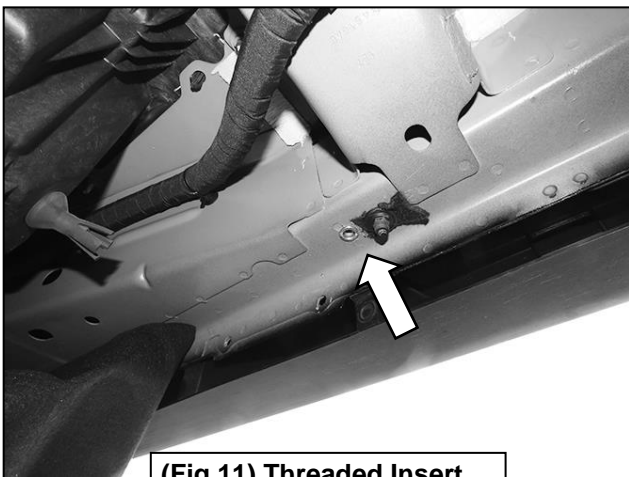

Fig 10



(Fig 11) Threaded Insert installed in the floor panel