



INSTALLATION INSTRUCTIONS

Premium Running Boards for Toyota Sienna 18-20

PART # PR-TY20

PARTS LIST:

1	Driver/Left side Running Board	2	10mm x 50mm "T" Bolts
1	Passenger/Right side Running Board	6	10mm Bent Threaded Rod Bolts
1	Driver/Left front Mounting Bracket	8	10mm Plastic Retainers
1	Passenger/Right front Mounting Bracket	2	10-1.5mm x 25mm Hex Bolts
1	Driver/Left front Support Bracket	10	10mm x 27mm x 3mm STD Flat Washers
1	Passenger/right front Support Bracket	4	10mm x 34mm x 3mm Large Flat Washers
1	Driver/left center Mounting Bracket	12	10mm Serrated Flange Nuts
1	Passenger/right center Mounting Bracket	12	6mm T-Bolts
1	Driver/Left rear Mounting Bracket	12	6mm x 22mm OD x 2mm Flat Washers
1	Passenger/right rear Mounting Bracket	12	6mm Lock Washers
2	10mm x 35mm button head Bolt Plates	12	6mm Hex Nuts

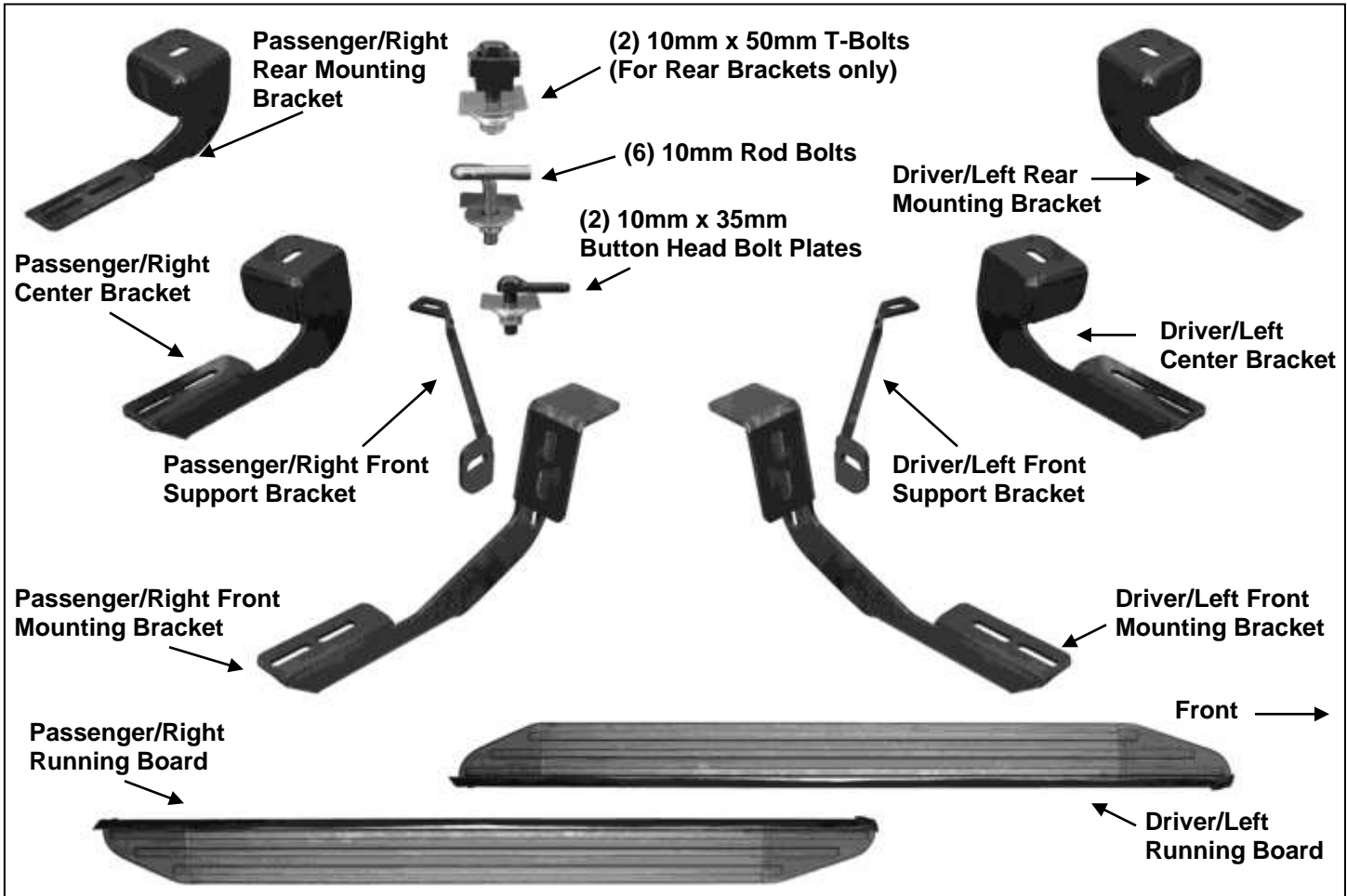

PROCEDURE:

1. REMOVE CONTENTS FROM BOX. VERIFY ALL PARTS ARE PRESENT. READ INSTRUCTIONS CAREFULLY BEFORE STARTING INSTALLATION. CUTTING IS REQUIRED. ASSISTANCE IS RECOMMENDED. PLEASE NOTE: 200LBS IS THE MAXIMUM RATED LOAD FOR THE VIEWPOINT RUNNING BOARDS.
2. Start installation under the driver side front of the vehicle. Remove the plastic cover, (Fig. 1). Pay close attention to the type and location of all factory hardware for reinstallation.
3. Locate the (2) factory holes in the inside wall of the floor panel, (Fig. 2). **NOTE:** The mounting locations may be covered by sealant or undercoating. Use a small screwdriver to poke through the sealant to uncover the hole. **IMPORTANT:** Brackets must sit flat against sheet metal. Scrape any excess sealant from body panel before installing any and all Brackets.
4. Select (1) 10mm Rod Bolt and (1) 10mm Plastic Retainer, (Fig. 3A). Partially thread the Retainer onto the Rod Bolt. Insert the Rod Bolt into the factory hole in the side panel, (Fig. 3B). Thread the Retainer

down until it is tight against the floor panel. The Retainer is designed to help hold the Rod Bolt in place during Bracket installation. Repeat this Step to install the second Rod Bolt in the remaining hole.

5. Hang the driver side Front Bracket from the (2) Rod Bolts with (2) 10mm x 34mm Large Flat Washers and (2) 10mm Flange Nuts, **(Fig. 4)**. Snug but do not tighten hardware at this time.
6. Next, remove the plastic plug from the bottom of the frame channel, **(Fig. 5)**. Select (1) 10mm button head Bolt Plate and (1) Plastic Retainer, **(Fig. 6A)**. Partially thread the Retainer onto the Bolt Plate. Insert the Bolt Plate into the hole in the bottom of the frame channel, **(Fig. 6B)**. Thread the Retainer down tight against the sheet metal to hold the Bolt Plate in place.
7. Select the driver side front Support Bracket. Secure the Bracket to the back of the front Mounting Bracket with (1) 10mm x 25mm Hex Bolt, (2) 10mm x 27mm STD Flat Washers and (1) 10mm Flange Nut, **(Fig. 7)**. Leave hardware loose at this time. Bolt the inner end of the Support Bracket to the Bolt Plate with (1) 10mm x 27mm STD Flat Washer and (1) 10mm Flange Nut, **(Fig. 8)**. Snug but do not fully tighten hardware at this time.
8. Move toward the center of the vehicle. Locate the factory hole in the bottom of the outer frame channel, **(Fig. 9)**. **NOTE:** Hole may be covered with sealant as described in **Step 3**. Select (1) 10mm Rod Bolt and (1) 10mm Plastic Retainer, **(Fig. 10A)**. Insert Rod Bolt into factory hole and tighten Retainer, **(Fig. 10B)**. Select the driver side Center Bracket, **(Fig. 11A)**. **IMPORTANT: the Center and Rear Brackets are similar, use Figure 11A to properly identify the Center and Rear Brackets.** Secure the Center Bracket to the Rod Bolt with (1) 10mm x 27mm STD Flat Washer and (1) 10mm Flange Nut, **(Fig. 11B)**. Snug but do not fully tighten hardware at this time.
9. Move to the rear mounting location and locate the large oval hole in the floor panel. Select (1) 10mm T-Bolt and (1) 10mm Plastic Retainer, **(Fig. 12A)**. Partially thread the Retainer onto the T-Bolt. Insert the T-Bolt into the oval hole in the floor panel and rotate Bolt 90-degrees so that the Block is across the oval hole, **(Fig. 12B)**. Thread the Retainer down until it is tight against the floor panel, **(Fig. 13)**. Select the driver side Rear Mounting Bracket, **(Fig. 11A)**. Secure the Bracket to the T-Bolt with (1) 10mm x 27mm STD Flat Washer and (1) 10mm Flange Nut, **(Fig. 14)**. Snug but do not fully tighten hardware at this time.
10. Carefully unwrap the Running Boards and select the driver side. Insert (6) 6mm T-Bolts into the slots in the end of the channels, (3 T-Bolts per channel), on the bottom of the Running Board, **(Fig. 15)**. Hold the Running Board up in approximate position and slide the T-Bolts down to line up with the Mounting Brackets. Tilt the Board up at a slight angle and push back against the vehicle until the T-Bolts fit into the slots on the Brackets. Secure the Board to the Brackets with (6) 6mm Flat Washers, (6) 6mm Lock Washers and (6) 6mm Hex Nuts, **(Fig. 16)**. Do not tighten hardware at this time. **NOTE:** the Running Board is designed to fit close to the vehicle. It may be necessary to temporarily loosen the Bracket hardware and tilt the Brackets downward to insert the Running Board.
11. Level and adjust the Running Board as desired and tighten all hardware **except** the hardware securing the front Support Bracket. Once all other hardware has been tightened, remove the front Support Bracket. Hold the plastic cover removed in **Step 6**, up in position. Trace the location of the front Bracket onto the cover, **(Fig. 17)**. Carefully cut the plastic cover to clear the Bracket, **(Fig. 18)**. **IMPORTANT:** Cut as little as possible from the cover. Reinstall the plastic cover with factory hardware. Reinstall the Support Bracket over the plastic cover as described in **Step 6**. Tighten all hardware.
12. Repeat **Steps 2 – 11** for passenger side Running Board installation.
13. Do periodic inspections to the installation to make sure that all hardware is secure and tight.

To protect your investment, wax this product after installing. Regular waxing is recommended to add a protective layer over the finish. Do not use any type of polish or wax that may contain abrasives that could damage the finish.

For stainless steel: Aluminum polish may be used to polish small scratches and scuffs on the finish. Mild soap may be used also to clean the Running Board.

Driver/Left Side Installation Pictured

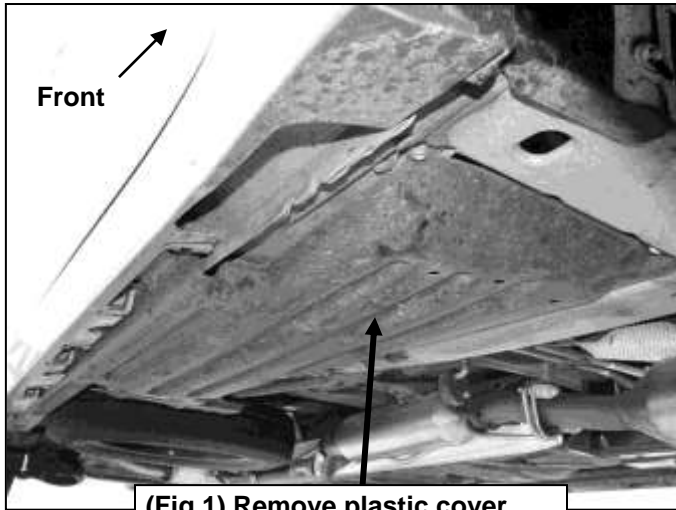

(Fig 1) Remove plastic cover.
NOTE: Passenger side pictured

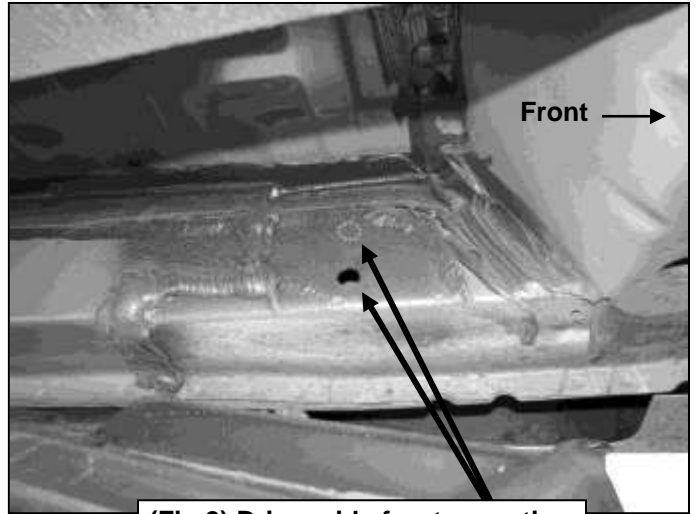

(Fig 2) Driver side front mounting
location pictured-remove sealant

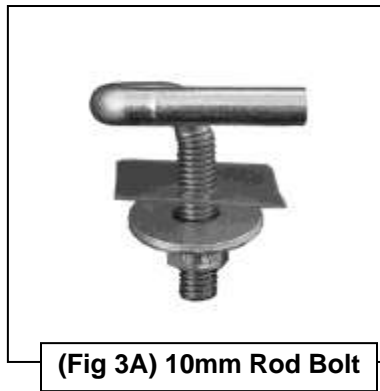

(Fig 3A) 10mm Rod Bolt

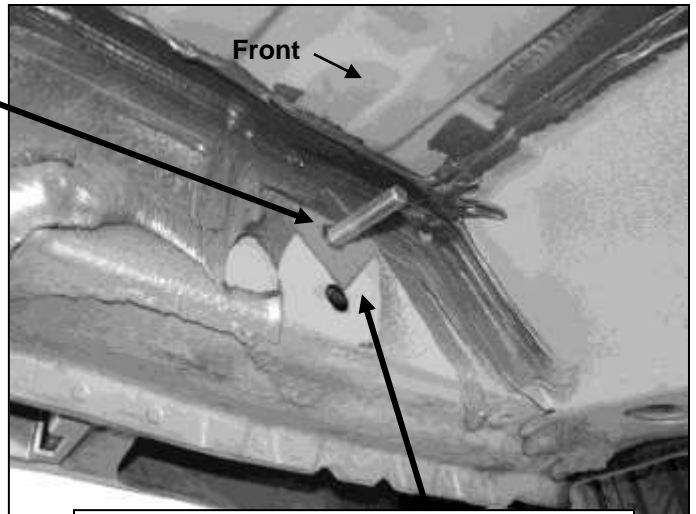

(Fig 3B) Use Plastic Retainer to hold Rod
Bolt in place during Bracket
Installation

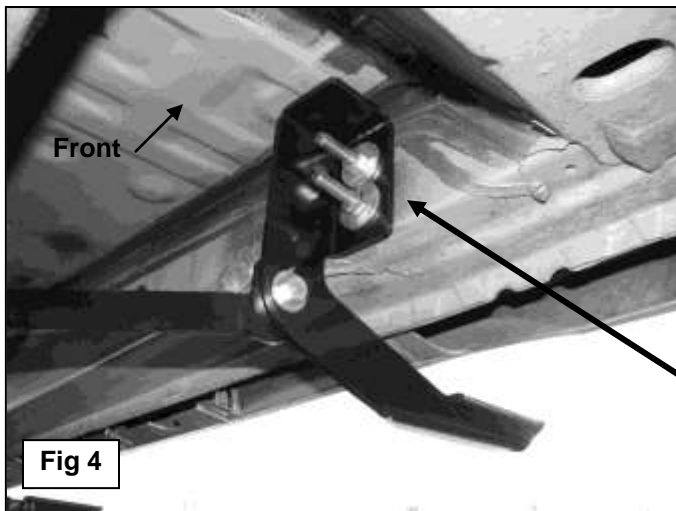
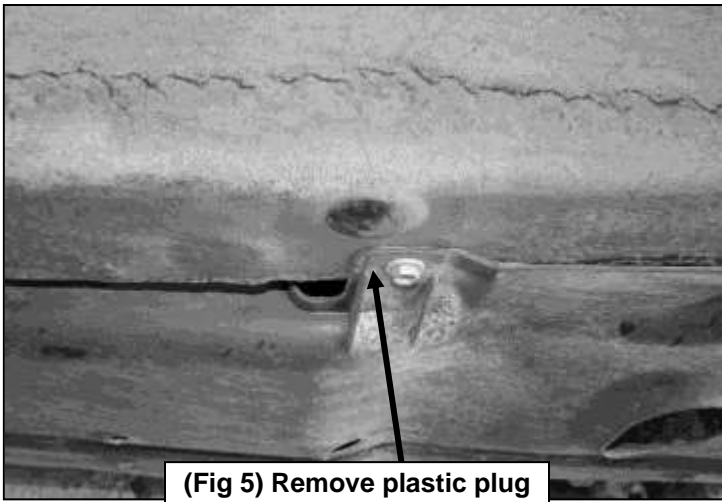

Fig 4

- (2) 10mm Rod Bolts
- (2) 10mm Plastic Retainers
- (2) 10mm Large Flat Washers
- (2) 10mm Flange Nuts

Driver Side Installation Pictured



(Fig 5) Remove plastic plug on bottom of frame channel



(Fig 6A) 10mm x 35mm Bolt Plate

10mm Hex Bolt
(2) 10mm STD Flat Washers
10mm Flange Nut

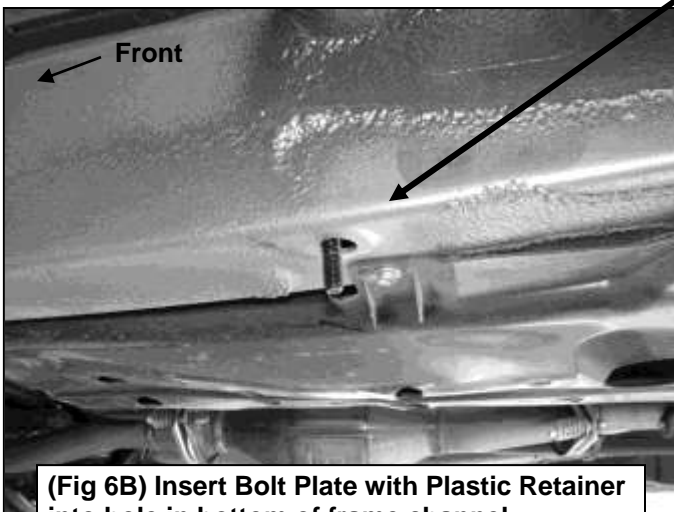

(Fig 6B) Insert Bolt Plate with Plastic Retainer into hole in bottom of frame channel

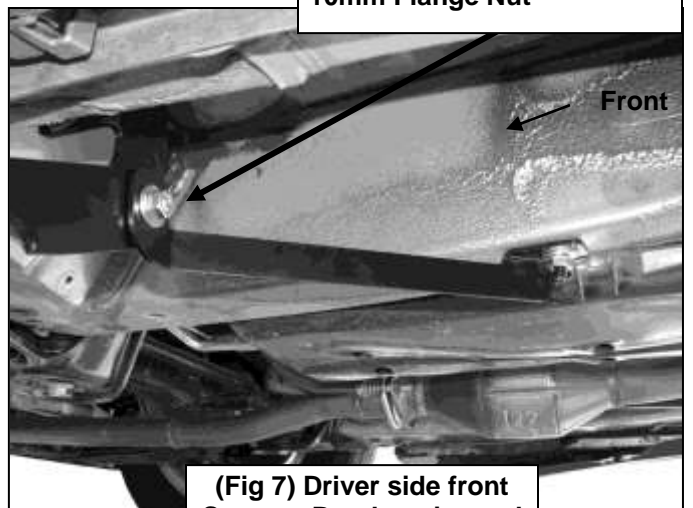

(Fig 7) Driver side front Support Bracket pictured

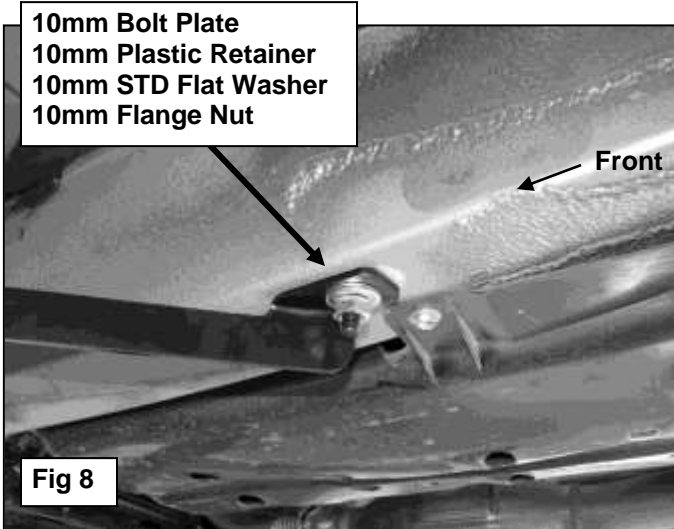

10mm Bolt Plate
10mm Plastic Retainer
10mm STD Flat Washer
10mm Flange Nut

Fig 8

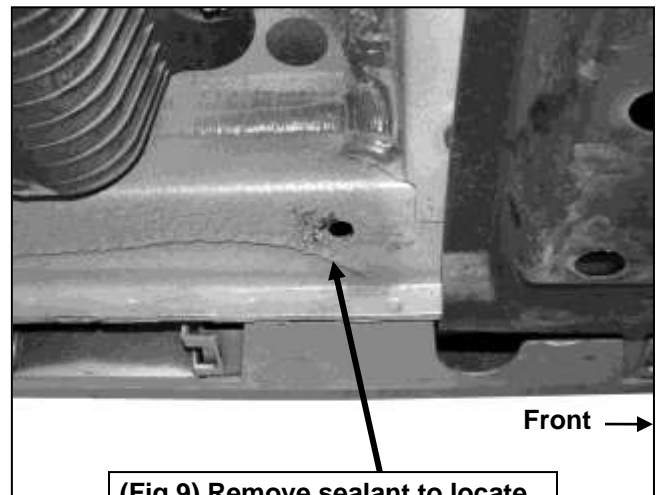

(Fig 9) Remove sealant to locate factory hole for center Bracket

Driver Side Installation Pictured

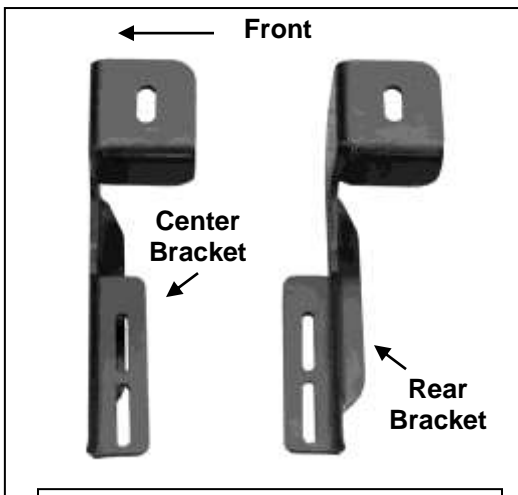
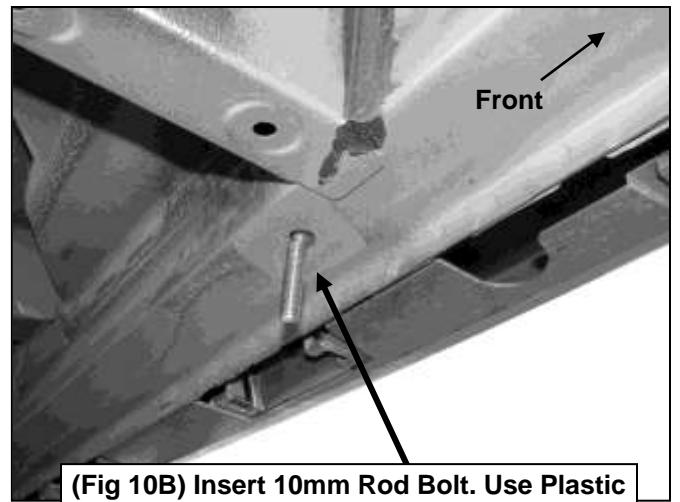

10mm Rod Bolt
10mm Plastic Retainer
10mm STD Flat Washer
10mm Flange Nut

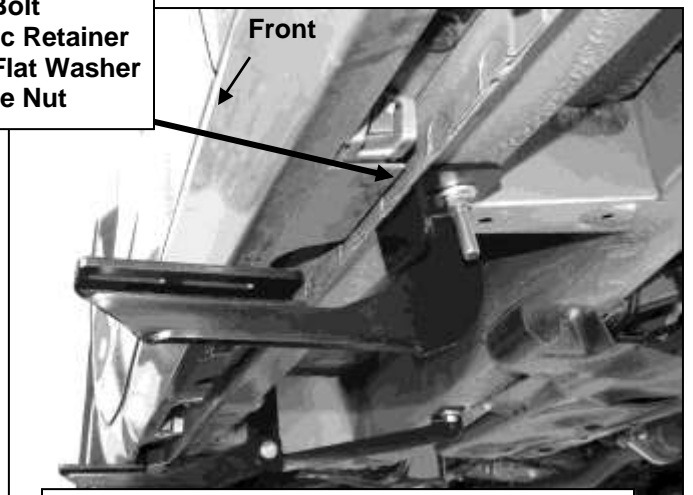

(Fig 11A) IMPORTANT: Driver side Center Bracket (cradle to rear) and Rear Bracket (cradle to front)

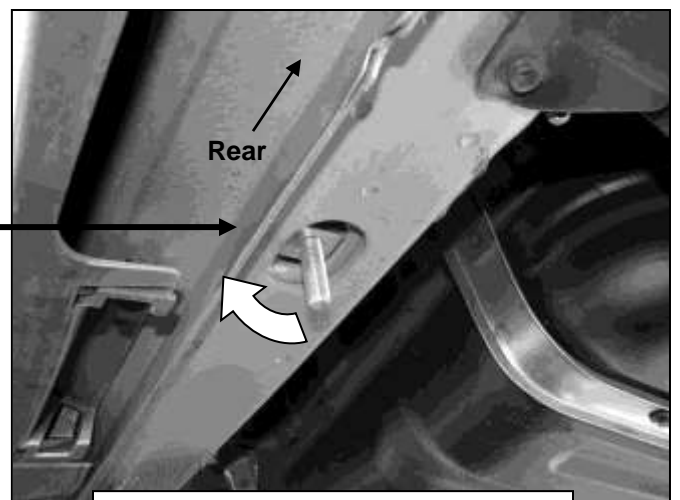

Driver Side Installation Pictured

