



**BLACK HORSE  
OFF ROAD®**

**TEL: 1-866-XANATOS**

## **INSTALLATION INSTRUCTIONS**

**LD2/MD1 FRONT BUMPER SKID PLATE  
19-21 CHEVY SILVERADO 1500**

**(Incl. 2022 1500 LTD & Excl. 2019 1500 LD and Diesel models)**

**PART# AFB-SI19-SK/ AFB-SI20-SK**

**PARTS LIST:**

1	LD2 Front Skid Plate
4	8mm x 25mm Button Head Bolts
4	8mm x 24mm x 2mm Flat Washers
4	8mm Lock Washer
1	5mm Wrench

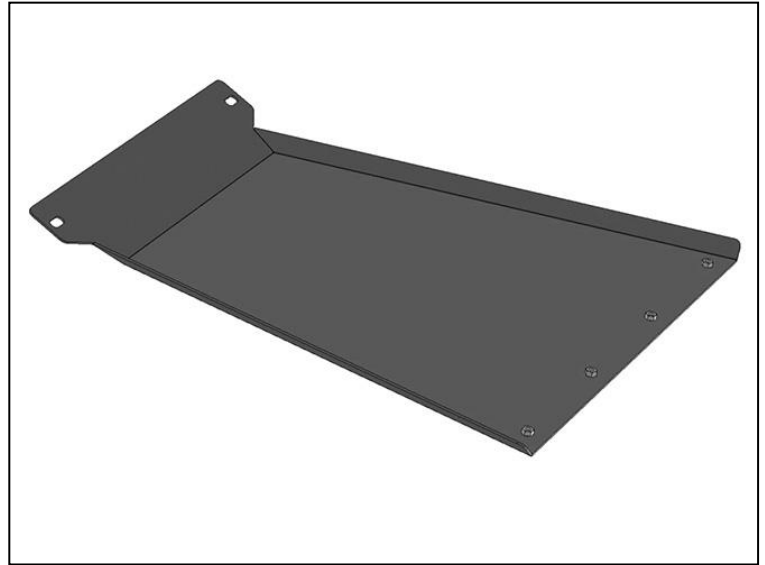

**PROCEDURE:**

**REMOVE CONTENTS FROM BOX. VERIFY ALL PARTS ARE PRESENT. READ INSTRUCTIONS CAREFULLY BEFORE STARTING INSTALLATION. ASSISTANCE IS RECOMMENDED.**

**CUTTING MAY BE REQUIRED.**

1. Carefully unwrap the Skid Plate. With assistance, line up the front of the Skid Plate with the back of the LD2 Bumper. Attach the Skid Plate to the Bumper with the included (4) 8mm Button Head Bolts, (4) 8mm Lock Washers and (4) 8mm Flat Washers, **(Figure 1)**. Leave hardware loose at this time.
2. Remove the (2) factory bolts attaching the plastic splash guard to the bottom of the crossmember, **(Figures 2 & 3)**. Reuse the (2) factory hex bolts to attach the Skid Plate to the splash guard and bottom of the crossmember, **(Figure 3)**. **NOTE:** If the Skid Plate does not lay flat against the splash guard, it may be necessary to cut the small plastic ribs off of the splash guard.
3. Level and adjust the Skid Plate and fully tighten all hardware, **(Figure 4)**.
4. Do periodic inspections to the installation to make sure that all hardware is secure and tight.

**To protect your investment**, wax this product after installing. Regular waxing is recommended to add a protective layer over the finish. Do not use any type of polish or wax that may contain abrasives that could damage the finish. Mild soap may be used to clean the Skid Plate.

- (4) 8mm Button Head Bolts
- (4) 8mm Lock Washers
- (4) 8mm Flat Washers

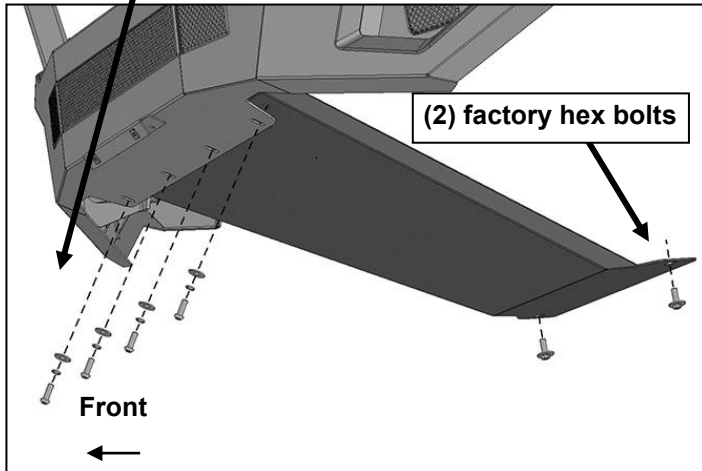

(Fig 1) Attach Skid Plate to back of Bumper and bottom of cross member (see Figure 3)



(Fig 2) Remove factory bolts attaching bottom of splash guard (arrow). Upper cover pictured

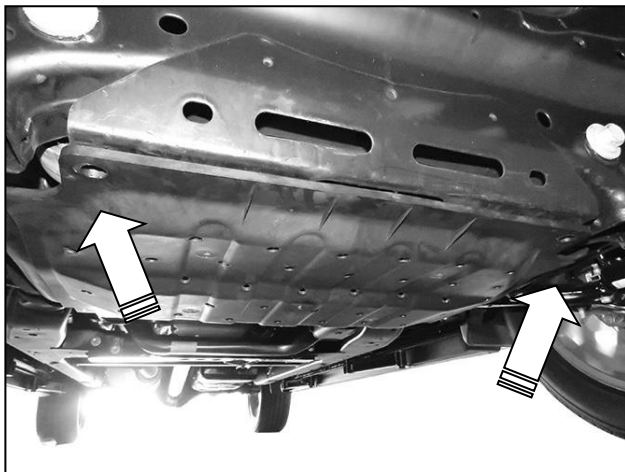

(Fig 3) Reuse (2) factory hex bolts to attach Skid Plate to threaded holes (arrows). Pictured from below cross member with upper splash guard removed

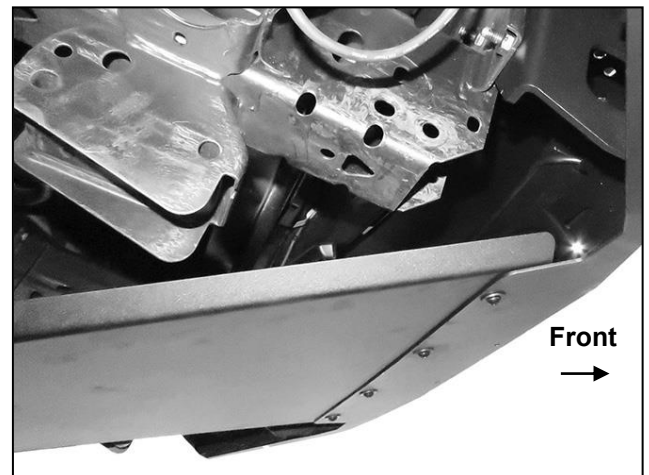

(Fig 4) Skid Plate fully installed