

76" PEAK PREMIUM RUNNING BOARD FOR 11-26 DURANGO (Excl. R/T, GT, GT Plus and SRT models)



TEL: 1-866-XANATOS

INSTALLATION INSTRUCTIONS
76" PEAK PREMIUM RUNNING BOARD FOR 11-26 DURANGO
(Excl. R/T, GT, GT Plus and SRT models)
PART # PEJPGC76
PROTECTED BY ONE OR MORE PATENT

Parts List:

1	Driver/ Left Running Board	12	6mm "T" Bolts
1	Passenger/Right Running Board	12	6-1.0mm x 25mm Hex Bolts
6	Mounting Brackets	24	6mm x 22mm OD x 2mm Large Flat Washers
6	12-1.75mm x 40mm Bolt Plates	12	6mm x 18mm OD x 1.6mm STD Flat Washers
6	12mm Serrated Flange Nuts	12	6mm Lock Washers
6	12mm x 24mm OD x 2.5mm Flat Washers	12	6mm Hex Nuts
6	12mm Plastic Retainers	12	6mm Nylon Lock Nuts

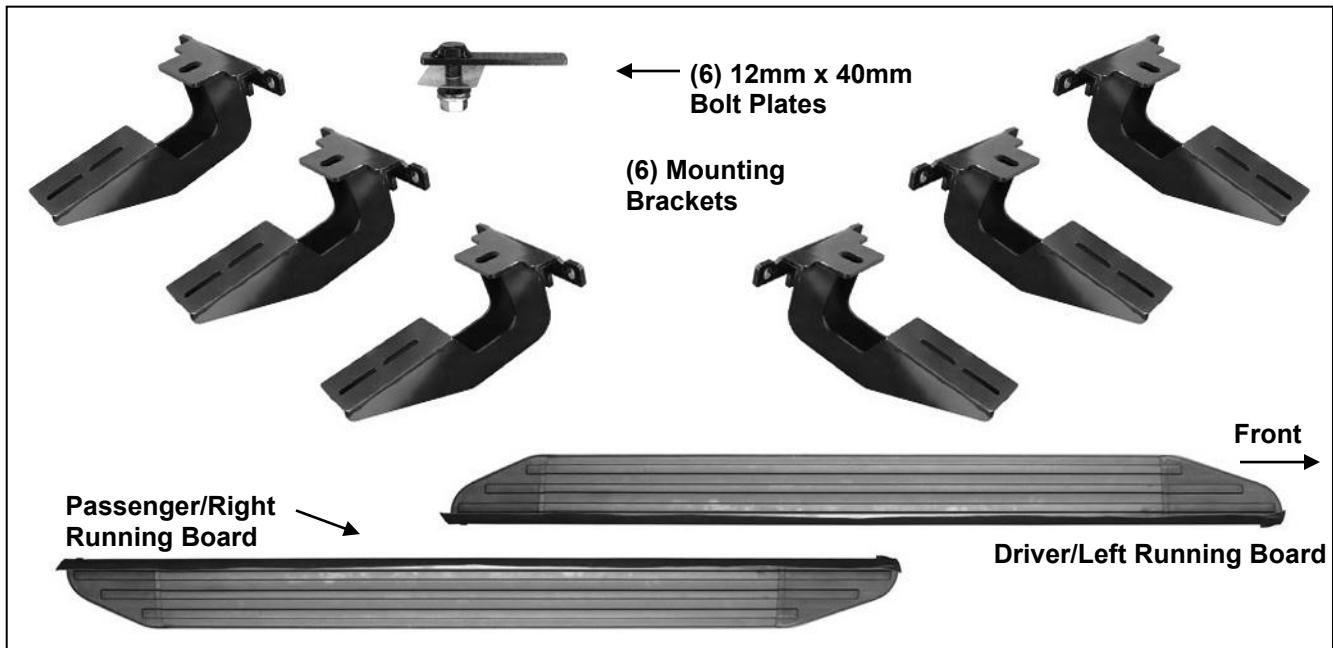
**PROCEDURE:**

REMOVE CONTENTS FROM BOX. VERIFY ALL PARTS ARE PRESENT. READ INSTRUCTIONS CAREFULLY BEFORE STARTING INSTALLATION. EXCLUDES SRT8 AND TRAILHAWK.

- Starting at the driver side, locate the (3) pairs of factory holes in the pinch weld, **(Figure 1 & 2)**. Move toward the front pair. Remove the rubber plug filling the oval hole in the bottom of the rocker panel in front of the two holes, **(Figure 3)**. Select (1) 12mm Bolt Plate and (1) 12mm Plastic Retainer. Partially thread the Retainer onto the Bolt Plate. Insert the Bolt Plate into the hole and rotate it 90-degrees to go across the slot, **(Figure 4)**. Thread the Retainer all the way down the Bolt Plate and tight against the body panel, **(Figure 5)**. **NOTE:** The Plastic Retainer is designed to prevent the Bolt Plate from falling into the body cavity and to aid in installing the Bracket.
- Select (1) Mounting Bracket and secure it to the Bolt Plate with (1) 12mm x 24mm Flat Washer and (1) 12mm Serrated Flange Nut, **(Figure 6)**. Do not tighten hardware at this time.
- Line up the (2) small slots in the Bracket with the (2) holes in the pinch weld. Insert (1) 6mm x 25mm Hex Bolt with (1) 6mm x 18mm STD Flat Washer through the pinch weld and then the Bracket. Secure the Bracket to the Hex Bolt with (1) 6mm x 22mm Large Flat Washer and (1) 6mm Nylon Lock Nut over the Bracket, **(Figures 6 & 9)**. Do not tighten hardware at this time. Repeat for remaining mounting hole in Bracket and pinch weld.
- NOTE:** Insert 6mm Hex Bolts with STD Flat Washers through the back of the pinch weld first, and then out through the Bracket. **IMPORTANT:** The passenger side of the vehicle may have a wiring harness attached behind the pinch weld, **(Figure 7)**. Remove the hex nuts and drop the harness down before installing the Brackets, **(Figure 8)**. 6mm Hex Bolts install from the inside first, then through the Bracket to clear the harness, **(Figure 9)**. Snug but do not fully tighten hardware at this time.
- Repeat **Steps 1 – 4** to install the center and rear Brackets, **(Figure 9)**.

76" PEAK PREMIUM RUNNING BOARD FOR 11-26 DURANGO (Excl. R/T, GT, GT Plus and SRT models)

6. Select the driver/left side Running Board. Locate the openings cut at the end of the slots on the bottom of the Running Board, (**Figure 10**). Insert (3) 6mm T-Bolts into each channel through the openings. Slide the T-Bolts into the approximate position in line with the (3) Brackets. Carefully place the Running Board in position on top of the Brackets. Slide the T-Bolts forward or back until they line up and drop into the slots on the Brackets. **NOTE:** It may be necessary to lower the Brackets to insert the Running Board. Loosen hardware as necessary.
7. Secure the Running Board to the Brackets with (6) 6mm x 22mm Large Flat Washers, (6) 6mm Lock Washers and (6) 6mm Hex Nuts, (**Figure 11**). Do not tighten hardware at this time.
8. Adjust and level the Running Board and tighten all hardware.
9. Repeat **Steps 1 – 8** for passenger/right Running Board installation. See important information in **Step 4**.
10. Do periodic inspections to the installation to make sure that all hardware is secure and tight.

To protect your investment, wax this product after installing. Regular waxing is recommended to add a protective layer over the finish. Do not use any type of polish or wax that may contain abrasives that could damage the finish.

For stainless steel: Aluminum polish may be used to polish small scratches and scuffs on the finish. Mild soap may be used also to clean the Running Board.

For gloss black finishes: Mild soap may be used to clean the Running Board.

Driver Side Installation Pictured

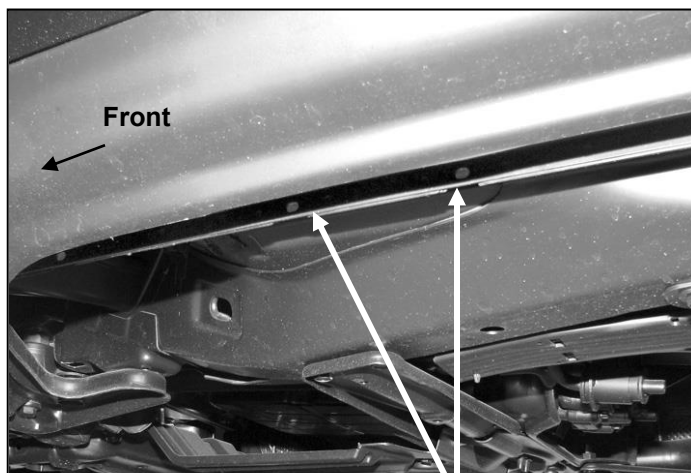

(Fig 1) Driver side front mounting location pictured

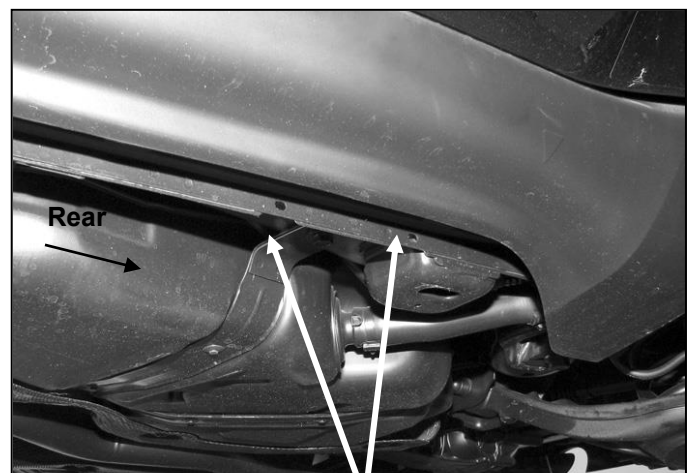

(Fig 2) Driver side rear mounting location pictured

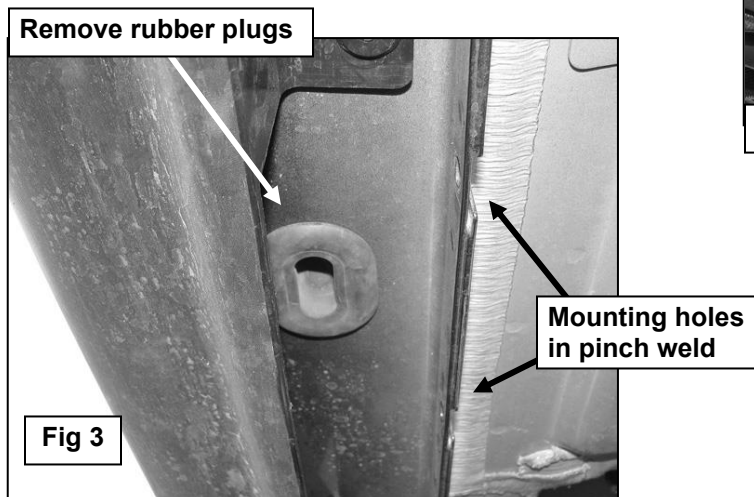

Remove rubber plugs

Mounting holes
in pinch weld

Fig 3

Driver Side Installation Pictured

- (1) 12mm x 40mm Bolt Plate
- (1) 12mm Plastic Retainer
- (1) 12mm x 24mm Flat Washer
- (1) 12mm Flange Nut

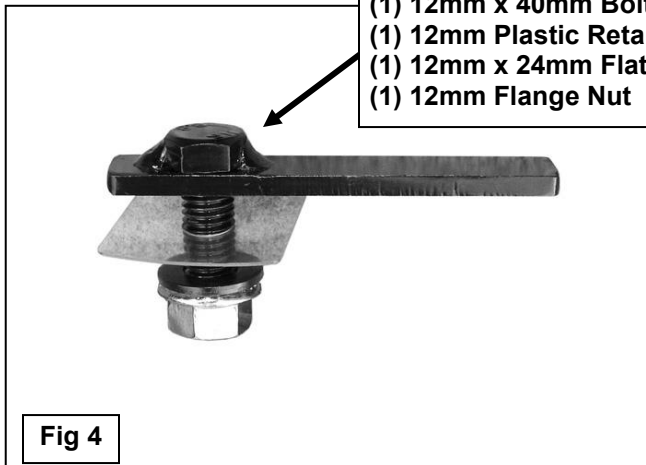

Fig 4

After inserting, rotate Bolt Plate 90-degrees to go across the slot or until Bolt Plate stops

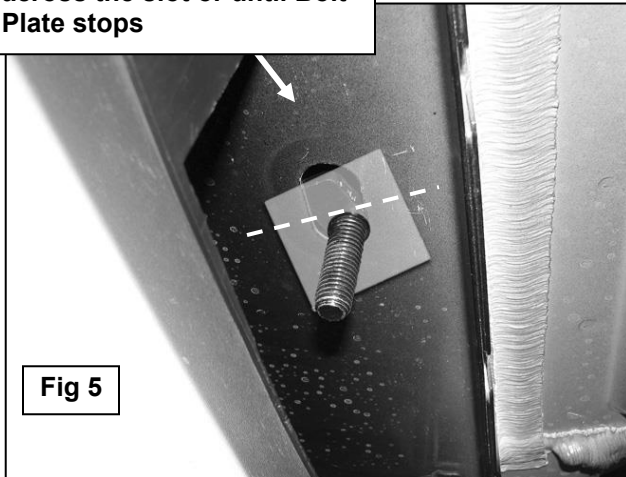

Fig 5

- 6mm x 25mm Hex Bolts
- 6mm x 18mm STD Flat Washers

- 6mm x 22mm Large Flat Washers
- 6mm Nylon Lock Nuts

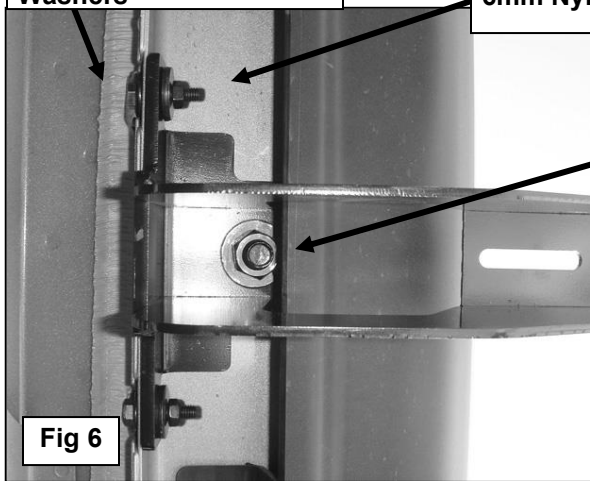
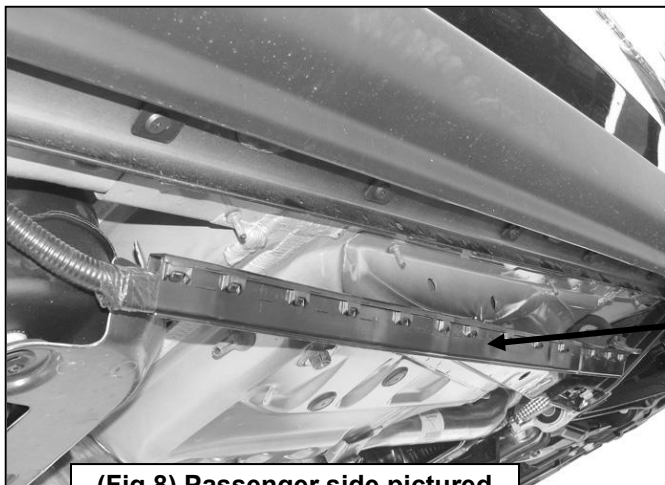

Fig 6

- (1) 12mm x 24mm Flat Washer
- (1) 12mm Flange Nut



(Fig 7) Passenger side pictured from below



(Fig 8) Passenger side pictured

Remove hex nuts from wiring harness. Drop harness down to install Brackets.

76" PEAK PREMIUM RUNNING BOARD FOR 11-26 DURANGO (Excl. R/T, GT, GT Plus and SRT models)

6mm x 25mm Hex Bolts
6mm x 18mm STD Flat Washers

6mm x 22mm Large Flat Washers
6mm Nylon Lock Nuts

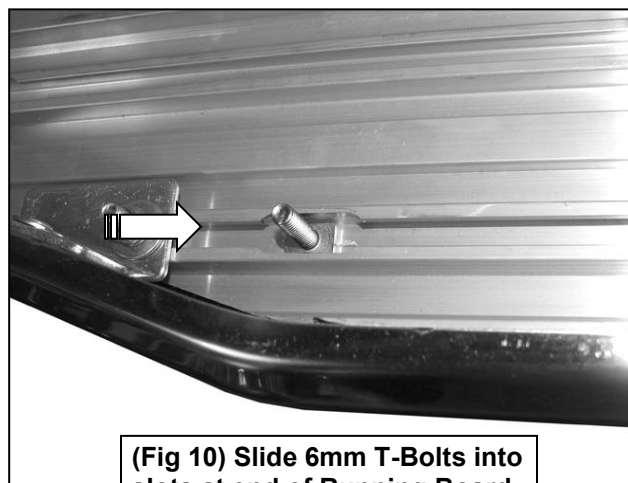
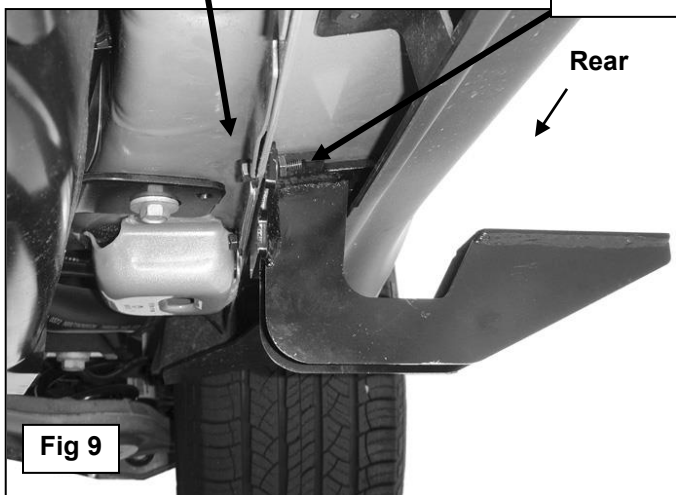

6mm x 22mm Large Flat Washer
6mm Lock Washer
6mm Hex Nut

